

ARIZONA DRIVER

THE ENTHUSIAST'S GUIDE TO LIFE BEHIND THE WHEEL

VOLUME 4 NUMBER 5
SEPTEMBER-OCTOBER 2005

HUMMER H3



Also:
2006
New Model
Preview



ARIZONA DRIVER

THE ENTHUSIAST'S GUIDE TO LIFE BEHIND THE WHEEL

CONTENTS

NEW VEHICLES

TEEN DRIVERS

VEHICLE INTRODUCTION

TEST DRIVE

MOTORCYCLE OVERVIEW

DEPARTMENTS



SEPTEMBER-OCTOBER 2005

2006 Model Year Preview 18

Almost 50 brands and 300 models are presented, giving an overview of changes, deletions and other news for the new model year. This issue includes brands from Acura through Jeep; the rest will be included in the next issue.
By Barbara and Bill Schaffer

Six Things a Teen Driver Should Never Be Without ... 26

This is a simple list, but could be vital in any number of bad situations, and bad situations do, indeed, happen. Take this list to heart, stock up the vehicle, and be ready.

HUMMER H3: Following the Path of its Forebears 28

Although we've been keeping an active eye out for the introduction of the H3T, a show truck from two years back, we tended to take the impending H3, smaller-than-H2-which-is-smaller-than-H1, with a grain of salt. Then we got a good education about a very impressive machine.
By Joe Sage

HUMMER H3: A HUMMER for any budget 34

The proof is in the pudding, so Barbara and Bill take the new HUMMER H3 through its paces. Let's find out what they learned in the process.
By Barbara and Bill Schaffer



XM Radio Standard on Harley-Davidson FLHTCUSE ... 38

Long distance touring becomes complete, with XM Satellite Radio now standard on the new Harley-Davidson FLHTCUSE Screamin' Eagle Ultra Classic Electra Glide®. 40 watts (80 watts optional) of power with 150 channels.

FROM THE PUBLISHER : START YOUR ENGINES 4

CAR SMARTS : QUIZ 7

AUTO NEWS UPDATE 10

DESTINATION DIRECTORY 17

THE INSIDE TRACK: BRIEFS & RUMORS 36

MOTOR RESOURCES DIRECTORY 40

UPCOMING FEATURES 42

COVER: HUMMER H3, photos courtesy GM, digital combo by Joe Sage.



START YOUR ENGINES : FROM THE PUBLISHER

The original was the HMMWV, the military's High Mobility Multipurpose Wheeled Vehicle, which revolutionized what had been the generic military jeep, the general purpose vehicle, with incredible ground clearance, self-inflating tires, and a low-accelerating but high-torque diesel engine. As the original general purpose vehicle (GP) begat the name "jeep" (well before it became a commercial brand), so the HMMWV acronym begat the name "Humvee," which was well known for awhile, but then was largely displaced by the HUMMER name, when AM General started producing the vehicle for public use. (Note that GM like the name spelled in all caps, which makes little sense in the face of the original acronym, but works with its in-your-face style. MINI likes the same thing, for opposite reasons, we suppose.) As General Motors has taken over, we have the H1, which is that original HMMWV- or Humvee-derived HUMMER, plus have now had the ubiquitous H2 for about three years, and next get the new, smaller-still H3 shown on our cover. Ironically, the vehicle known for wretched excess (a good thing to some, not so to others) keeps expanding toward the smaller end. (And yes, there are tales of a possible H4 on the horizon, but it remains to be seen how small they will go.) In this issue, we showcase the new H3. Wretched excess redux? Or just right?

We also bring you a complete overview of the new 2006 model year's vehicle offerings, with almost 50 brands and 300 models represented. In fact, it's so complete that it's incomplete—we run from Acura to Jeep in this issue, and we'll

bring you the rest, Kia through Volvo, in November/December. Enjoy the drive.



Joe Sage
Publisher/Executive Editor

ARIZONA DRIVER

MAGAZINE

PUBLISHER/EXECUTIVE EDITOR:

Joe Sage

CONTRIBUTING WRITERS:

Jill Amadio, Pilar Covarrubias, Mark Cox, Larry Edsall, Dan J. Gardner, Gary Goldzweig, Bob Kroener, Jim Rogers, Bill & Barbara Schaffer, Tim Sharp

CONTRIBUTING PHOTOGRAPHERS:

Jean-Pierre Brietta, Rich Cox, Luis DeBonoPaula, Larry Edsall, Dan J. Gardner, Randy Lorentzen, Jim Pyle, Dick Reed

DESIGN & PRODUCTION: AdZoneAZ

ADVERTISING SALES: 480-948-0200

ARIZONA DRIVER MAGAZINE

PUBLISHED BIMONTHLY BY ADZONE ARIZONA LLC
Arizona Driver Magazine
PO Box 13387 - Scottsdale AZ 85267
www.azdrivermag.com

Arizona Driver Magazine and Arizona Rider Magazine are registered trademarks of AdZone Arizona LLC.

ARIZONA DRIVER

THE ENTHUSIAST'S GUIDE TO LIFE BEHIND THE WHEEL



Where the roads are dry and the cars are slick.

Arizona Driver Magazine
PO Box 13387
Scottsdale AZ 85267
480-948-0200
www.azdrivermag.com



1. What was the average price of a used car in 2004?
a. \$5,412 b. \$7,992
c. \$9,229 d. \$10,167

5. According to a recent Scarborough Research survey, what percentage of new vehicle buyers plan to buy an oversized vehicle (i.e. SUV, minivan or pickup truck)?
a. 29 percent b. 41 percent
c. 53 percent d. 60 percent

6. What model year was the last Shelby GT500 produced?
a. 1967 b. 1970
c. 1973 d. 1976

4. How many miles of wire are in a typical new car?
a. 1 mile b. 2 miles
c. 3 miles d. 4 miles

5. How many years has the Mercury Sable been on the market?
a. 21 years b. 19 years
c. 17 years d. 15 years

6. What percentage of vehicles sold today have more than 200 horsepower?
a. 9 percent b. 28 percent
c. 41 percent d. 54 percent

7. Ford has started recommending that tires be replaced, even if they are not worn out, after what period of time?
a. 4 years b. 6 years
c. 8 years d. 10 years

5. Which automaker has the most Top 10 Vehicle Assembly Plants for 2004?
a. General Motors b. Nissan
c. Ford d. Toyota

6. Who is the only automaker currently offering a seven-speed automatic transmission in several passenger cars and SUVs?
a. Audi b. Bentley
c. Mercedes-Benz d. BMW

7. What percentage of the cars sold in the US in 2004 were built by transplant manufactures – i.e. foreign companies like Toyota, Honda, and BMW that have established plants in the US?
a. 9.0 percent b. 16.2 percent
c. 21.8 percent d. 25.6 percent

1. How many vehicles are available in the US that have an EPA-estimated highway fuel economy rating of 30 mpg or more?
a. 25 models b. 50 models
c. 75 models d. 100 models

3. When NHTSA started doing rollover ratings of SUVs and light trucks five years ago, one vehicle earned a four star rating; how many have four star ratings now?
a. 10 vehicles b. 16 vehicles
c. 24 vehicles d. 30 vehicles

4. How much did the price of an average vehicle increase for 2005 in the US market?
a. \$255 b. \$449
c. \$563 d. \$719

5. Which vehicle brand logged the largest average price increase for the 2005 model year?
a. Audi b. HUMMER
c. BMW d. Mercedes-Benz

2. Thru the first six months of 2005, which auto maker is listing the largest percentage of increase in sales over 2004?
a. Subaru
b. Hyundai Group (Kia & Hyundai)
c. Nissan (includes Infiniti)
d. Toyota (Includes Lexus & Scion)

7. How many miles of Interstate toll roads are there in the US?
a. 875 miles b. 1,688 miles
c. 2,896 miles d. 5,114 miles

1. What percentage of minivans sold in the US in 2004 were from US auto makers?
a. 69.8 percent b. 59.8 percent
c. 49.8 percent d. 39.8 percent

4. What percentage of drivers ages 21 and older reported driving under the influence of alcohol or illicit drugs during the past year?
a. 6.6 percent b. 16.6 percent
c. 26.6 percent d. 36.6 percent

5. Which automaker had the most vehicles on the list of most stolen cars in 2004?
a. Acura b. Audi
c. BMW d. Cadillac

6. What impact did the 'Employee discount' sales program have on General Motors sales in the first month, June 2005, over June 2004 figures?
a. Sales up 15.9% b. Sales up 31.9%
c. Sales up 46.9% d. Sales up 58.1%

1. During the first month of the General Motors Employee Pricing Program, which brand had the largest percentage of sales increase over June 2004?
a. HUMMER b. GMC
c. Cadillac d. Saab

3. Who was the main spokesman for Chrysler's employee pricing advertising which began in July 2005?
a. Jerry Seinfeld b. Lee Iacocca
c. Jay Leno d. Mario Andretti

4. Where is the safest place for your pet to sit when riding in your vehicle?
a. On the driver's lap
b. Front passenger seat beside the driver
c. In the rear seat
d. In the back, if it is a pickup truck

1. How many Acura NSX sports cars have been sold in the United States since it was first introduced in 1991?
a. 8,854 b. 28,854
c. 58,854 d. 88,854

2. In which James Bond movie did 007 drive an American car?
a. "You Only Live Twice"
b. "The Man with the Golden Gun"
c. "The Spy Who Loved Me."
d. "For Your Eyes Only"

3. What is the slogan on the Wyoming state vehicle license plates?
a. Home of Yellowstone
b. Vacationland
c. none
d. Great Places

5. What percentage of used vehicle buyers, who use the Internet, go to the Kelley Blue Book (www.kbb.com) web site?
a. 15 percent
b. 35 percent
c. 55 percent
d. 75 percent

ANSWERS ON PAGE 8 >>

>> ANSWERS (quiz on page 7) >>



1. Answer: b. According to the Automotive News 2005 Market Data Book the average price of a used car in 2004 was \$7,992. The average truck sold for \$9,179.
5. Answer: c. According to a recent Scarborough Research survey, 53 percent of new vehicle buyers planned to buy a larger vehicle (29 percent SUV, 12 percent pickup truck and 12 percent van or minivan).
6. Answer: b. The last model year for the Shelby GT500 was 1970. That will soon change, because Ford will be bringing it back in 2006 as a 2007 model.
4. Answer: a. According to GE Advance Materials, every car that rolls off the assembly line today has more than 1 mile of wire running through it.
5. Answer: b. Ford has been producing the Mercury Sable since 1986, or for 19 years. Production was halted in April 2005 and is being replaced by the Montego and upcoming Milan sedans.

6. Answer: d. According to Progressive Insurance Group 54 percent of the passenger cars sold today have more than 200 horsepower. That compares with nine percent in 1990.

7. Answer: b. According to Automotive News Ford Motor Co. has started recommending that tires be replaced after six years of normal use because they degrade over time. DaimlerChrysler is about to do the same.

5. Answer: a. According to the Harbour Report for 2004 GM has four (1st, 4th, 5th and 9th) of the top 10 most efficient assembly plants in the US. Nissan was second with three, while Ford, Toyota and Chrysler each had one.

6. Answer: c. Mercedes-Benz is the only manufacturer currently offering a seven-speed automatic transmission on several models of their passenger cars and SUVs.

7. Answer: c. According to Automotive News Data Center, 21.8 percent of the new cars sold in the US in 2004 were built by transplant manufacturers.

1. Answer: d. According to The Alliance of Automobile Manufacturers there are more than 100 models sold in the US that have a highway EPA fuel economy rating of 30 mpg or more.

3. Answer: c. According to the NHTSA (National Highway Traffic Safety Administration) there was only one SUV and light truck with a four star rollover rating when the agency started testing rollovers about five years ago. Now there are 24 vehicles with four star ratings.

4. Answer: c. According to Automotive News the average price of a vehicle sold in the US in 2005 went up \$563, or 2.05 percent. That compares with \$440 in 2004; \$681 in 2003 and \$255 in 2002.

5. Answer: b. According to Automotive News HUMMER raised its prices an average of \$3,196 for 2005, or 6.36 percent. Mercedes-Benz prices went up an average \$2,830; Audi — \$1,816; BMW — \$1,405.

2. Answer: c. With a 14.8 percent increase over 2003 Nissan had the largest percentage increase in sales for the first six months of 2004. Toyota — 10.9 percent. Hyundai — 7.8 percent. Subaru — 5.8 percent.

7. Answer: c. According to Motor Trend magazine there are 2,896 miles of Interstate toll roads in the United States as of January 1, 2003.

1. Answer: b. 59.8 percent of the minivans sold in the US in 2004 were made by the Big 3 American car manufacturers.

4. Answer: b. According to the Substance Abuse and Mental Health Services Administration 16.6 percent of adult drivers ages 21 or older reported driving while under the influence of alcohol or illicit drugs during the past year.

5. Answer: a. According to CCC Information Services Inc. there were eight Acura Integra models on the list of 25 most stolen vehicles in 2004. BMW — 3. Cadillac — 3. Audi, Mercedes-Benz and Lexus each had 2. The list is compiled from total loss claims of 350 insurance companies.

6. Answer: c. General Motors has a 46.9 percent sales increase in June 2005 over June 2004 with its 'employee discount' program in which buyers got the same price as GM employees, often with other incentives.

1. Answer: a. According to General Motors figures HUMMER had the largest gain in sales during the first month of the Employee Pricing program with an increase of 198.6 percent over 2004. GMC — 84.8 percent. Cadillac — 63.8 percent. Saab — 57.2 percent. Other GM brand results were Buick — 31.1 percent. Chevrolet — 42.5 percent. Saturn — 33.4 percent. Pontiac — 17.4 percent loss.

3. Answer: b. Ex-Chrysler chairman Lee Iacocca appeared in three Chrysler commercials in July for the company's employee discount pricing program.

4. Answer: c. According to information distributed by Chrysler division, the safest place for a pet to sit in a vehicle is in the back seat away from the driver so that it minimizes distractions that can cause accidents.

1. Answer: a. Only 8,854 Acura NSX sports cars have been sold in the United States since 1991. The NSX will be discontinued after this model year and it will be replaced, some time in the future, with an ultra high performance vehicle.

2. Answer: b. In the James Bond movie "The Man with the Golden Gun" Bond drove an AMC Hornet hatchback special. He used it to jump a canal using a broken bridge, and for an added twist, the car did a barrel roll as it flew over the water. Speaking of flying, at the end of this chase scene, the bad guy got away in a flying AMC Matador coupe.

3. Answer: c. There is no slogan on the Wyoming license plate, but there is a silhouette of a cowboy on a bucking horse to break up the numbers.

5. Answer: c. According to a J.D. Power and Associates study, 55 percent of the used car buyers who use the Internet to help them shop, go to the Kelley Blue Book web site.

The Car Smarts quiz includes news and trivia from industry sources, trade journals and consumer magazines compiled for *Arizona Driver* by **BILL & BARBARA SCHAFFER** of *Auto Digest*.



NISSAN'S NEW SMALLEST CARS

In an effort to take advantage of the market success of the Toyota Scion division, Nissan is planning three sub-Sentra size models for the US market. Nissan is showing a stylish four-seat hatchback that could be the basis for the company's smallest US offering. The so-called Sport concept is based on the Renault Mégane II (Renault is Nissan's parent company), with the design being done by Nissan's newest design studio in Farmington Hills, Michigan. The car looks like a rally car with its sharp angles, bulging fenders and hood, along with top-mounted spoiler. Nissan is not confirming the Sport concept will be built, but there appears to be a market, if the Scion success is any indication. With the exception of the carbon-fiber composite body and 20-inch wheels, it is built from existing parts, which means it could be easily made ready for sale. If Nissan builds the Sport concept in two or three years, pricing is likely to be in the \$16,000 range, or about the same as the Scion tC coupe. The Sport concept is one of three recent reveals by Nissan. The Azeal coupe was unveiled at the Detroit show, the Sport concept bowed in New York and the Actic people-mover concept debuted at Detroit in 2004. All three youth-oriented cars are based on the parent company's Renault Megane platform and are aimed directly at the three Scion cars. The Sport is similar in size to the Volkswagen Golf, while the Actic is about the size of the Cube minivan from Japan or the Scion xB. According to Nissan Design Chief Shiro Nakamura, the three are likely to start being rolled out before Nissan releases a replacement for the Sentra. ▼



Sport concept



Actic concept



Azeal concept



Lotus Exige

Lots of style and all performance, the new Lotus Exige trims off some of the pounds of the already-flyweight Elise, upping the power-to-weight ratio.

A NICHE LOTUS

▲ Lotus says some prospective buyers think the Elise it's too plush and want something more racy. With that thought in mind, Lotus Group CEO Kim Ogaard-Nielsen says the company is adding another model that is like an "Elise on steroids." The Exige, which has been sold in Europe since last fall, is basically a racing version of the Elise. It has a hardtop bolted in place to replace the Elise convertible top. It also gets some more extreme bodywork including diffusers and spoilers to increase down force along with suspension and performance enhancements. Lotus plans to import about 150 copies of this special model to the US annually at the base price of nearly \$50,000 or about \$7,000 more than the Elise.

BMW TAKES THE HIRE TO THE COMICS

From 2001 through 2003 BMW marketing broke new ground by creating a series of exciting short films each produced by a different A-list filmmaker and distributed over the Internet. The eight films, called The Hire, generally involved an unnamed driver, simply referred to as The Driver, completing a variety of tasks, often involving beautiful women in peril and always with a car chase involving a BMW.

The films developed a cult-like following and were downloaded more than 75 million times. They have also been released in a DVD collection. Due to the popularity of the films, BMW has brought back The Hire in a different format—comics. The six comics have The Driver in a series of new assignments, but instead of driving existing models, he is seen in imaginary BMW concept cars. The comics are being published by Dark Horse Comics, and may be purchased online at bmwfilms.com for \$2.99 each. BMW officials maintain the films and comics are attracting attention from a younger new generation of potential BMW consumers. All proceeds from the sale of the films and comics are going to charity.

TWO NEW CAR-BASED JEEPS

Jeep will add two car-based vehicles to its lineup in 2006. Although details are not clear, one of the new Jeeps is expected to be an entry level all-wheel drive (AWD) designed to compete with the Subaru Forester. The other AWD model will be a taller roofline and look more like an SUV and will go up against the Toyota RAV4, Honda CR-V, Ford Escape and several other vehicles in that category. Both cars are being developed on the same platform as the Dodge Caliber

crossover wagon, which is scheduled to replace the Neon in March 2006.

MITSUBISHI HAS BIG PLANS

Mitsubishi has six new products planned for introduction within the next 26 months, says Mitsubishi president Rich Gilligan. According to AutoWeek magazine the list is expected to include the Eclipse (which is already at dealers, a Raider pickup in August, Eclipse Spyder in January 2006, new Outlander later in 2006, Lancer in the winter 2006-7 and the Lancer Evo in 2007. The marketing program refers to the Mitsubishi lineup as "j-cool" which refers to all things cool and Japanese.

MERCEDES-BENZ NEW S-CLASS

Mercedes has released the first photos of the next generation S-Class, which is scheduled to debut this fall in Europe and in the US early in 2006. The sleek new design takes cues from the dramatic Mercedes CLS sedan and the Maybach ultra luxury sedan. The 2007 model cars get a new generation V-8 engine with 382-hp for the S500 and a 500 plus horsepower V-12 for the top-of-the line S600. New technology abounds with

KEEP RIGHT >>



BEST SPEED VALUE: CORVETTE Z06

Dollar for dollar, there will be no better performance value on the market once the new Chevrolet Corvette Z06 goes on sale during the fourth quarter of 2005. With the bargain price of \$65,800 and a 0 to 60 mph acceleration time of 3.7 seconds (and there are rumors it's even faster than that) this supercar will not only be the best value, it will be one of the fastest cars available on the market – period. The Z06 was developed alongside the C6.R racecar and uses advanced lightweight materials typically found only in the most exotic sports cars. Powered by a hand-built 7.0-liter (505-hp) V-8 engine and outfitted with special brakes, suspension, tires and other performance equipment, the Z06 is also the fastest car ever produced by General Motors. Weight saving materials, like carbon fiber, aluminum, magnesium and titanium, help bring the weight down to only 3,132 pounds netting a weight-to-power ratio of 6.2 pounds per horsepower. ▼

Chevrolet Corvette Z06



Dodge HEMI® 5.7 liter V-8

All this, and gas economy too? Chrysler and Dodge HEMI® engines outfitted with the Multi Displacement System run on 4 cylinders during low loads.

>> AUTO NEWS UPDATE - cont'd

features like the optional Distronic Plus system that maintains a pre-set following distance behind the vehicle ahead and also activates a new Brake Assist Plus system applying the ideal pressure, even if the driver presses the brake pedal too lightly. Mercedes claims the system will reduce rear collisions in heavier city traffic by up to 75 percent. The same system includes a park assist with six radar sensors mounted behind the bumpers eliminating the visible "portholes" of previous ultrasonic-based systems. It has an optional infra-red night vision option along with many other safety and convenience features.

DODGE WILL CHALLENGE MUSTANG

Dodge has announced plans to bring back another name from the 70s and mount it on a two-door competitor for the hot selling Ford Mustang coupe. Although the name is not yet official, industry insiders speculate the Challenger name will be used on the new coupe which will be derived from the same LX platform being used for the Chrysler 300 and Dodge Magnum. The coupe is expected

to debut in 2009 around the same time the 300 and Magnum are scheduled for re-engineering and re-styling. Chrysler believes they can sell 60,000 to 70,000 coupes annually.

DODGE INJECTS MDS INTO RAM

▲ Not all Chrysler V-8 engines are created equal. For example, Hemi engines used in the Chrysler 300, Dodge Magnum and Dodge Charger have the Multi Displacement System (MDS) technology that seamlessly cuts off one bank of cylinders and operates as a four-cylinder engine during low load periods like cruising or going down hills. The result is a fuel savings of about 20 percent. MDS was not available on the Ram trucks, but now the 2006 model Hemi Ram trucks will get the same MDS system and respective fuel savings for their 5.7-liter, 345-hp V-8 Hemi engines. We expect the same technology will appear in the Hemi-powered Jeep Grand Cherokee soon.

DAIMLERCHRYSLER PLAYS DIESEL CARD

DaimlerChrysler has plans to add diesel engine options to many of its vehicles as early as 2008; and that movement could provide the impetus to push other

manufacturers to diesel. The move started with the success of the Mercedes-Benz E320 CDI diesel last year and will be expanded to the M-Class and G-Class SUVs along with the upcoming R-Class sport wagon. In addition to the Jeep Liberty diesel, insiders say there are plans to add the more fuel efficient engines to the Chrysler 300 and the Jeep Grand Cherokee. In order to meet the tougher new EPA emissions standards the DaimlerChrysler diesels are expected to use the urea injection system that shoots ammonialike acid into the exhaust system to clean the emissions. According to Automotive News the urea changes the pollution causing oxides to nitrogen (NOx) and water.

VOLVO'S NEW HARDTOP CONVERTIBLE

Volvo plans to reveal the second generation C70 convertible at the Frankfurt Motor Show in September. "We've succeeded in creating an attractive convertible which, at the mere touch of a button, converts into an equally elegant coupe. The customer gets two cars in one. Both with space for four

KEEP RIGHT >>

Pontiac Grand Prix GXP



Seeking performance with front-wheel drive, Larger front tires on the Grand Prix GXP are an updated approach to Pontiac's "wide-tracking" heritage.

>> AUTO NEWS UPDATE - cont'd

adults," says Volvo Cars President and CEO Hans-Olov Olsson. The advance body structure of the new C70 allows industry leading safety features like a new door-mounted inflatable curtain which even works with the top down. The sleek new design was developed in a joint venture with Italian design company Pininfarina. Torsional rigidity has doubled over the last generation car and with the top up it's increased an additional 10 to 15 percent. A 215-hp, turbocharged five-cylinder engine powers the new C70.

VOLVO DEVELOPS ADVANCED INLINE 6

Ford-owned Volvo is developing a new inline six-cylinder engines that will power the next generation S80 sedan and will likely find its way into Ford and Jaguar models, too. The light-weight aluminum six is developed for use in traverse and longitudinal applications Code-named the SI6, the engine uses a four-valve-per cylinder configuration with a compact chain-drive camshaft resulting in an engine that is shorter than the current Volvo five-cylinder engine. Three versions of the engine are planned: a naturally

aspired 3.2-liter rated at 238 hp, a 3.0-liter light pressure turbocharged version rated at 285-hp, and a high-pressure turbo producing 350-hp.

THE CAR WITH LARGER FRONT TIRES

▲ Check out the new Pontiac Grand Prix GXP sedan and you'll find an anomaly for performance cars – the wheels and tires on the front are larger than those on the back. According to Pontiac the combination of 8x18-inch wheels with 255/45R18 tires on the front with smaller 7x18-inch wheels and 225/50R18 on the rear gives the front-wheel drive sedan "more neutral cornering characteristics, while bolstering overall handling and braking capability." The GXP is powered by a 290-hp 5.3-liter V-8 which makes it the most powerful front-wheel drive sport sedan currently sold in the US.

BUGATTI: THE WORLD'S FASTEST CAR

The Bugatti Veyron EB 16.4, prototypes have some remarkable performance figures. For example: 0 to 60 mph in under 3.0 seconds; 0 to 124 mph in 6.0 seconds; 0 to 186 mph in 14.0 seconds; 194 mph braking to 50 mph and then accelerating back to 194 mph in 22

seconds. Rumors have the car capable of a top speed of 252 mph. When braking from speeds over 124 mph a rear wing snaps to a 70-degree angle in 0.4 second once the brakes are applied and provide 0.6 g of deceleration. Bugatti officials say it will stop from 252 mph in less than 10 seconds. The Volkswagen-owned Bugatti is powered by a 1000-hp 8.0 liter, V-16 engine with four turbochargers. Speculators peg the price somewhere between \$700,000 and \$1.5 million when it goes on sale late in 2005. Quantities are expected to be limited to 300.

WAIT FOR MERCEDES 6.3-LITER V-8

The magicians at the Mercedes-Benz AMG division have created a new naturally aspired V-8 engine that produces "a minimum" of 510 horsepower and 464-lb.ft. of torque. According to AutoWeek magazine the engine and cylinder heads are high-strength aluminum made from state-of-the-art metallurgical technology. The cylinder walls undergo a process to minimize friction, increase durability and add strength. The throaty-sounding engine was developed by AMG alone and is not only more powerful than the 5.4-



Hyundai Entourage

Hyundai enters the minivan market knowing that safety is a top priority for American families, hence a full complement of airbags front, back, sides.

liter V-8 it replaces, but it's also 47 pounds lighter. AMG has the capacity to produce about 24,000 of the new 6.3-liter engines annually. They will likely find their way into virtually all the high performance models replacing the supercharged V-8s. Look for the first US application to be in the AMG version M-Class due in the US next year. All models with the new engine will get a special 6.3-liter badge.

INFINITI SMALL FX STYLE CROSSOVER

Infiniti is expected to offer new smaller version crossover vehicles similar to the FX35 and FX45s to compete with vehicles like the BMW X3. The new vehicles will be called the CX25 and CX35. They will be powered by a 2.5-liter four-cylinder engine and 3.5-liter V-6. Styling will take cues from the FX series. The crossovers will be built on shortened versions of the next generation platform to be used by the Infiniti FX, M45, G35 along with the Nissan 350Z and the upcoming Skyline GT-R. There is speculation that the four-cylinder version may get a supercharged version, and that a hybrid may also be in the mix. The CX models are aimed at the popular BMW

X3, but Acura and Cadillac both have similar style products planned for introduction in a similar time frame.

HYUNDAI'S ENTOURAGE MINIVAN

▲ It appears that Hyundai will finally get a minivan. As expected the new Hyundai Entourage minivan will be built on the same chassis as the sister company's Kia Sedona. The Entourage will be powered by the same 3.8-liter 265 hp V-6 engine that will be used in the upcoming Azera premium sedan. The Entourage will be filled with standard safety features like stability and traction control, anti-lock brakes with brake force distribution, six airbags including side curtains and active front head restraints. It's expected to arrive at dealerships in the spring of 2006 as a 2007 model.

PORSCHE CLUB 911 CLUB COUPE

Porsche is building a 50th Anniversary of Porsche Club of America (PCA) 911 Club Coupe. Limited to 50 models, the Club Coupe will be the first of the current production run to get the X51 PowerKit which boosts horsepower from 355 to 381 and torque from 295 to 306 lb.ft. It also gets a special Azurro California color

replicating the azure blue made popular on Porsche 356 sports cars 50 years ago. With a base price of \$99,911, the Club Coupe is also filled with dozens of other cosmetic and performance enhancements. The Club Coupes will be offered to PCA members first with the unclaimed cars offered to the general public.

GM MOVING UP TRUCK INTROS

General Motors is moving up the development of the next generation of full-size trucks and SUVs to help turn around the company's profitability and better compete against other new products. Initially, the changeover was scheduled for the 2008 model year, but it appears they will now be unveiling some models as early as the Detroit auto show in January 2006. The new 5.3-liter and 6.0-liter V-8 engines both will get much needed Displacement on Demand (DOD) technology which is expected to make significant improvements in fuel economy. The standard 4.6-liter V-6 will not get the new DOD. All the trucks are expected to get major improvements to interior quality to interior materials and fit and finish.

KEEP RIGHT >>



Saab 9-3 SportSedan and 9-3 SportCombi

The Saab 9-3 SportSedan and SportCombi wagon retain familiar styling cues inside and out. This year they are slated to be joined by the 9-3 Aero.

SAAB'S NEW 9-3 AERO

▲ The 2006 Saab Aero gets a new turbo-charged 3.6-liter V-6 engine developed on the same all-aluminum block that fills the Cadillac CTS engine compartment. The 250-hp engine has virtually no turbo lag or torque steer. The Aero goes on sale in October with a choice of a six-speed manual or six-speed automatic transmission with steering wheel shift buttons. Other than the new engine, new five-spoke 17-inch wheels and larger roll bars at both ends, the Aero is identical to the 2005 model. Pricing will be around \$34,300. A convertible and SportCombi (wagon) will be available in December.

CHEVROLET'S SS STRATEGY

Chevrolet won't have an SS model of each of their vehicles, but there will be at least eight within the next year or two. Currently on the books there's the impressive supercharged Cobalt SS, the unique 390-hp SSR roadster truck and the Silverado SS truck with its 345-hp 6.0-liter V-8. For 2006 look for the all new front-drive Impala SS powered by a 5.3-liter 303 hp V-8, a Malibu Maxx SS with a 240 hp 3.9-liter V-6 and a Monte Carlo SS coupe with the 303-hp V-8. Although it's not official

yet, there will likely be an SS version of the upcoming HHR with the same 240-hp supercharged four-cylinder engine bound for the Pontiac Solstice. Finally there's the TrailBlazer SS complete with a 6.0-liter 391 horsepower. GM expects to sell about 125,000 SS models annually.

THE BUILD BOOK

An entrepreneurial couple from Sherman Oaks, Calif., Scott and BJ Killeen have created a unique automotive publication. The Build Book is like a thick, glossy magazine, but as Scott points out in his Publisher's Note, it's technically defined as a serial because it's an ongoing project. It's actually a story of a custom car, "From Concept to Reality". Book 1 documents the process of building Joe Ragan's (TV's "Fear Factor" host) 1970 'Cuda. For 180 pages the Killeen's document in text and full color photos nearly every step of the process of taking the 1970 Plymouth Barracuda from under a blue tarp in Elgin, Ill. through the entire impassioned building progression to create a world class custom the "Sick Fish" Cuda. The car was built by Troy Trepanier of Rad Rides by Troy and was designed by Chip Foose of Foose Design. Books are

currently in the works for a '35 Roadster being built by Rods and Customs in Hummelstown, Penn., a '61 Starliner and a '69 Camaro. The Build Book is a must for custom car fans and collectors. Copies are available at www.buildbookusa.com.

WHAT CAN YOU HEMI?

In a contest called "What can you Hemi?" Chrysler asked people to imagine what they'd like to see a Hemi engine installed in. More than 360 dreamers submitted ideas to Chrysler and the winning entry was a massive "Big Wheels"-style tricycle with a Hemi installed behind the rear wheels. Marcus Braun of Vancouver, BC took home a new Chrysler 300C Hemi as the top winner. The four other finalists included a Hemi Snow blower, Hemi-Go-Round (carousel), Hemi (paper) Shredder and Hemi on Ice (Hemi-powered Zamboni to refinish ice rinks). Chrysler engineers actually built working versions of all top five entries and displayed them at Chrysler's annual full line media preview. ■

Auto News Update includes a summary of auto news from industry sources, trade journals and consumer magazines compiled for *Arizona Driver* by **BILL & BARBARA SCHAFFER** of *Auto Digest*.

Arizona

ATTRACTIONS & EVENTS

Chiricahua State Park
HCR 2, Box 6500 • Willcox AZ 85643
520-824-3560

Grand Canyon National Park
PO Box 129 • Grand Canyon AZ 86023
923-638-7888 Visitor Info Recorded Message

Lake Havasu State Park
699 London Bridge Dr. • Lake Havasu AZ 86403
928-855-2784

Organ Pipe Cactus National Monument
10 Organ Pipe Drive • Ajo AZ 85321-9626
520-387-6849 Visitor Information

Petrified Forest National Park
PO Box 2217
Petrified Forest National Park AZ 86028
928-524-66228 Visitor Information

Saguaro National Park
3693 South Old Spanish Trail
520-733-5153 Visitor Info Rincon Mtn District

Sport Compact Drag Racing
Every thursday at Firebird Raceway
www.dragracing.com/phx

Wupatki National Monument
Flagstaff Area National Monuments
6400 N. Hwy 89 • Flagstaff AZ 86004
928-679-2365 Visitor Information
928-526-1157 Visitor Information, HQ

California

ATTRACTIONS & EVENTS

Palm Desert Visitor Information Center
72-990 Highway 111 • Palm Desert CA 92260
800-873-2428 • www.palm-desert.org

MOTOR MUSEUMS

Petersen Automotive Museum
6060 Wilshire Blvd. (at Fairfax) • LA CA 90036
323-930-CARS • www.petersen.org

Colorado

ATTRACTIONS & EVENTS

Colorado Activity Centers, Inc.
737 N. Tenmile Drive - Suite 35
PO Box 129 • Frisco CO 80443
800-777-8642 - www.coloradoinfo.com

MOTOR MUSEUMS

Shelby American Collection
5020 Chaparral Court
PO Box 19228 • Boulder CO 80308-2228
www.shelbyamericancollection.org
303-516-9565

Nevada

ATTRACTIONS & EVENTS

Las Vegas Tourism Bureau
6120 W. Tropicana Ave. • Las Vegas NV
www.lasvegastourism.com

MOTOR MUSEUMS

Imperial Palace Auto Collections
Fifth floor parking facility of Imperial Palace.
702-794-3174
www.imperialpalace.com/auto.html

National Automobile Museum

The Harrah Collection
10 Lake Street South • Reno NV 89501
775-333-9300 • www.automuseum.org

New Mexico

ATTRACTIONS & EVENTS

New Mexico Department of Tourism
800-733-6396 x 0643 • www.newmexico.org

Santa Fe Chamber of Commerce
PO Box 1928 • Santa Fe NM 87504
8380 Cerrillos Rd. Suite 302 • Santa Fe NM 87507
505-983-7317 • www.santafechamber.com

RESORTS / LODGING

Inn on La Loma Plaza
315 Ranchitos Road • Box 4159 • Taos NM 87571
800-530-3040 • www.VacationTaos.com

Inn on the Alameda
303 East Alameda • Santa Fe NM 87501
505-984-21221 • www.innonthealameda.com

Utah

ATTRACTIONS & EVENTS

San Juan County Tourism
117 S. Main Street • Monticello UT 84535
800-574-4386 • www.southeastutah.org

Southern Utah Scenic Tours
PO Box 1113 • Cedar City UT 84720
888-404-8687 • www.utahscenictours.com

RESORTS / LODGING

Desert Rose Inn & Cabins
701 W. Highway 191 • Bluff UT 84512
888-475-7673 • www.DesertRoseInn.com

Mexico

RESORTS / LODGING

Puerto Peñasco Mexico Online
Beachfront home rentals in Rocky Point.
623-935-0507 • www.puerto-penasco.com

ATTRACTIONS & EVENTS

Baja California State Tourism Office
Blvd. Diaz Ordaz s/n
Edificio Plaza Patria Nivel 3
CP 22400 Tijuana BC
(66) 81-9492

Chihuahua State Tourism Office
Calle Libertad No. 1300
Edificio Agustin Melgar, 1er Piso
CP 31000 Chihuahua, Chihuahua
(14) 29-3421

Sinaloa State Tourism Office
Av. Camarón Sabalo esq. Tiburon
Edificio Banrural 4 Piso
CP 82100 Mazatlán, Sinaloa
(69) 16-5160

Sonora State Tourism Office
Centro de Gobierno
Edificio Estatal Norte 3er Nivel
Comonfort y Paseo Río
CP 83280 Hermosillo, Sonora
(62) 17-0076

Of national interest

MOTOR MUSEUMS

Henry Ford Museum & Greenfield Village
20900 Oakwood Blvd. • Dearborn MI 48124
www.hfmgv.com • 313-271-1620

Imperial Palace Auto Collections
(see Nevada listings)

Motorcycle Hall of Fame Museum
Pickerington OH 43147
www.motorcyclemuseum.org • 614-856-2222

National Automobile Museum
(see Nevada listings)

National Corvette Museum
350 Corvette Drive • Bowling Green KY 42101
www.corvettemuseum.com • 800-53VETTE

Petersen Automotive Museum
(see California listings)

Shelby American Collection
(see Colorado listings)



Information is derived from a variety of sources and may not be final or accurate; check all info. Listings do not necessarily represent any specific affiliation with nor endorsement by *Arizona Driver* magazine.

2006 NEW MODEL YEAR PREVIEW PART 1

by Barbara and Bill Schaffer

SEE PART 2: November/December issue

The automotive industry may seem as if it's always in a state of pandemonium with new models and vehicle categories sprouting up faster than dandelions on a fresh mowed lawn. This not only makes the industry interesting, but it's a great advantage for the buyer because there's likely a new car, truck, SUV or van that's just right for you. Also with models coming and going so quickly there are bound to be some good clearance sales along the way.

With pledges of innovation and an abundance of new top management, the auto industry should be even more exciting in the next few years.

We've gathered basic information on 49 brands and about 300 models of the new 2006 vehicles. The prices listed are base prices to give you an idea of the manufacturers' suggested retail prices (MSRP) before options.

Lexus LF-C Concept

ACURA

MDX – Acura's SUV crossover style SUV gets minor evolutionary changes for 2006. All models have a new six-year, 70,000-mile limited powertrain warranty.\$37,300 to \$44,300 (est.)

NSX.....Discontinued

RL – All new last year, the Acura flagship is loaded with hi-tech equipment and features like the most advance all-wheel drive (AWD) system available. The Super Handling AWD not only distributes the torque between the front and rear axles, but between the left and right rear tires to provide better cornering, handing and stability.\$49,600 (est.)

RSX – Acura's sporty small coupe is unchanged for 2006. It comes in standard trim with a 155-hp four-cylinder engine or the Type-S performance version with 201-hp.\$20,940 to \$24,460

TL – Entering its second year of a new design the entry luxury sedan is the best selling vehicle in the segment. With virtually no options other than a color choice and a navigation system, the TL is one of the best equipped vehicles on the market and an excellent value.\$33,500 to \$35,800 (est.)

TSX – The entry-level sedan get gets evolutionary changes for 2006 including more horsepower (201), enhanced styling and more interior features like a hands free wireless telephone interface and faster navigation system.\$27,500 to \$29,500 (est.)

ASTON MARTIN

DB9 Coupe/Volante convertible – As two of the sexiest sports cars on the market the DB9s get minor changes for 2006.\$161,100 to \$174,100

Vanquish S – Aston Martin flagship, the Vanquish S, is one of the most advanced sport cars in the world. It has 2+2 seating and is powered by a 460-hp V-12 engine with a six-speed automatic shifting manual . It gets minor enhancements. ...Base price \$255,000

Vantage – All new for 2006 the Vantage is like a smaller version of the DB9 with its body made of steel, aluminum and composites. The engine, which is based on the Jaguar V-8, produces 380-hp and is capable of 175 mph and 0 to 62 mph in 4.9 seconds. A convertible version will arrive in 2007 or 2008....\$110,000

AUDI

A3 – The company that made all-wheel drive famous with its state-of-the-art quattro, starts off 2006 early with the introduction of the new smaller A3 five-door. The first models arriving mid-year were powered by the new potent 2.0-liter four cylinder turbocharged engine with a choice of six speed manual transmission, or the innovative new DSG (Direct Shift Gearbox), but only with

front-wheel drive. Come December a 3.2-liter V-6 engine lands in the U.S. with the quattro option.\$24,740 to \$26,140

TT – The exciting two-seat TT coupe and roadster remains unchanged except for a new red interior color on the coupe. The TT comes with three engine options, two four-cylinders rated at 180 and 225 horsepower along with a 250-hp V-6 model.\$33,500 to \$43,640

A4 – Entering into the second year of its product cycle, the A4 is still available in three versions, the convertible, sedan and Avant (wagon). For 2006 all models get a Bluetooth enhancement to the phone system along with minor, mostly cosmetic changes. Three new models are listed in the A4 column: an A4 3.2 quattro six-speed manual sedan and Avant along with a front-wheel drive 3.2 V-6 with the efficient Continuously Variable Transmission (CVT) which was only available previously with a four-cylinder engine.\$33,500 to \$43,640

A6 – The mid-level Audi A6 gets two new models for 2006: an Avant 3.2 Tiptronic quattro and a front-wheel drive with the multitronic CVT. The S-Line package, which includes a sport suspension and trim enhancements, is now available for both V-6 and V-8 models. Adaptive cruise control and adaptable air suspension are now options.\$41,900 to \$53,770

A8 – Two models of the award winning A8 flagship are again available for 2006. The V-8-powered A8 and the awesome A8L with its W12 (12-cylinder) engine both get the new single-frame grille, adaptive air suspension, adaptive front lights along with a few other technical and cosmetic upgrades.\$66,590 to \$118,190

Q7 – While still unofficial, Audi will soon announce final details on the Q7 sport utility vehicle, which was derived from the sister company's Volkswagen Touareg.t.b.d.

S4 – The high performance S4 models are unchanged other than similar enhancements to those on the A4 models and the addition of a V-8 badge designating the 4.2-liter V-8 engine lurking beneath the hood.\$45,850 to \$55,840

BENTLEY

Arnage – The high-end Arnage remains unchanged, but Bentley has confirmed that a production Arnage Drophead Coupe will be on sale within a year.\$201,000 to \$240,000

Continental GT and Flying Spur – As the most talked about luxury coupe to come along in years, the Bentley Continental GT sprouts wings and two more doors for 2006 with the debut of the Flying Spur sedan. With

KEEP RIGHT >>

Acura RL



Acura TSX



Aston Martin Vanquish



Audi A3



Audi Q7



Bentley Flying Spur



its sleek styling directly influenced by the GT, the new four-door promises to gather as much praise as the GT did when it debuted last year. As with the GT, power will come from the 552-hp 6.0-liter V-12 engine driving a six-speed automatic and all-wheel drive to a top speed in the 190 mph range and 0 to 60 mph time of about five seconds. A GT convertible is also in the works.\$164,000

BMW

3 Series — The legendary BMW 3 Series sedan got a complete makeover for 2006 and debuted this summer. All-wheel drive versions and a wagon will be available this fall. Coupes and convertibles will be unchanged until the 2007 model year with some upgrades for '06. The rumored V-8 powered M3 is due also for '07.\$31,595 to \$45,595

5 Series — We saw the debut of the all new six-cylinder 5 Series sedans in the spring of 2005, and now the V-8 powered models are due this fall. The previous 545i model has been replaced with a new 550i model and is powered by a 4.8-liter 360-hp V-8. It also gets upgrades to the iDrive controller, Dynamic Stability Control system and the key system is changed to the engine Start/Stop button feature that is currently being used on the BMW 7 and 3 Series sedans. An all-new M5 will be available this fall powered by a 507-hp 5-liter V-10-engine. It will also have a new 7-speed SMGIII gearbox which changes gears 20 percent faster than the previous generation SMGII.\$43,195 to \$58,095

6 Series — The stylish 6 Series coupe and convertible both get rebadged for 2006 as 650i models to reflect the engine change to the same 4.8-liter V-8 as the 5 and 7 Series sedans. Both cars also get the new Start/Stop system, Dynamic Stability Control enhancements along with some cosmetic and color changes.\$72,495 to \$79,496

7 Series — The flagship 7 Series 750i, 750Li, 760i, and 760Li models were introduced in the spring of 2005 and remain virtually unchanged for 2006.\$72,495 to \$119,595

X3 & X5 — Both the X3 and X5 Sports Activity Vehicles get minor model revisions for next year.\$37,495 for the X3\$43,195 to \$71,795 for the X5

Z4 — BMW's two-seat roadster gets a mild facelift for 2006 and there is still a rumor of a possible M high-performance model. But, the big news is a possible coupe version to compete with the new Porsche Cayman.\$35,495 to \$42,495.

BMW is also expected to announce a new crossover vehicle to be built in the South Carolina plant.

BUGATTI

Veyron — Due later this year is the Bugatti Veyron, Volkswagen's most outrageous car. The two-seater Bugatti comes with a 1001-hp W-16 engine which is expected to propel the Veyron to 252 mph.\$1,240,000 (est.)

BUICK

LaCrosse — The mid-level LaCrosse was introduced in 2005, but for '06 it gets standard side curtain airbags on all models.\$22,835 to \$28,435

Lucerne — Replacing the Park Avenue and LeSabre at the top of the Buick food chain for 2006 is the all new Lucerne. The Lucerne is a fresh approach to the entry-luxury sedan utilizing GM technological advances like Magnetic Ride Control, StabiliTrak DVD navigation system. It's also the first Buick in more than 10 years to get a V-8 (275-hp) engine option in addition to the standard 197-hp 3.8-liter V-6 and a similar configuration to the dearly departed Oldsmobile Aurora. Like other new Buick models the Lucerne gets the company's new Quiet Tuning.\$36,000 to \$43,000 (est.)

Rainier — The Buick Rainier represents the luxury side of the GM SUV brands. It faces its third year in the competitive SUV market with electronic safety enhancements along with an upgraded interior. Power still comes from a 275-hp in-line 4.2-liter six-cylinder engine or a higher torque 5.3-liter 300-hp V-8.\$33,075 to \$35,610

Rendezvous — A more powerful base engine and a Consumer Reports Annual Auto Issue "Recommended" rating are the highlights of the 2006 model Rendezvous crossover. Other changes include a new exterior and revised grill design.\$26,595 to \$39,415

Terraza — The latest addition to the Buick truck portfolio is the Terraza Crossover Sport Van which makes a strong luxury statement for the GM fleet with elegant interior, upgraded safety equipment and more power for 2006.\$27,790 to \$33,875

CADILLAC

CTS — The first car to receive the "Art & Science" treatment in 2003 is the CTS. For 2006 it gets minor technical and cosmetic changes. The high performance "V" version V-8 engine has been bumped up to 6.0-liters, still with 400 horsepower. The CTS-V is one of the three cars Cadillac boosts will accelerate from 0 to 60 mph in less than 4.6 seconds...in this case its an impressive 4.6 seconds.\$30,190 to \$50,675

DTS — The full-size DTS sedan replaces the DeVille. Now the only front-wheel drive car in the lineup, the DTS is powered by a choice of two Northstar V-8 engines and is filled with new technology like MagneRide suspension

BMW 3 Series



BMW X5



Bugatti Veyron



Buick Lucerne



Buick Terraza



Cadillac DTS



and radar guided cruise control. Available in a variety of trim levels, the DTS fits a wide spectrum of drivers from the traditional Cadillac buyer to more demanding drivers that want extra space.\$41,990 to \$50,490

Escalade, ESV & EXT — The full-size Escalade SUV, the longer ESV and the EXT sport utility truck are all unchanged for this model year, but new versions are in the works for a 2007.\$58,805 to \$70,175 for the ESV\$53,335 for the EXT

SRX — Cadillac's stylish on-road SUV, the SRX gets a standard power rear liftgate along with cosmetic revisions.\$38,340 to \$52,035

STS — New in 2005 the STS gets a few enhancements for '06 including an all-wheel drive option with the V-6 powered model. The STS-V adds an entirely new dimension to the Cadillac flagship sedan with the addition of a 4.4-liter supercharged Northstar V-8 producing 469 horsepower.\$40,525 to \$70,000 (est.)

XLR — Cadillac's luxury hardtop/roadster, the XLR, gets a new adaptive lighting system and enhancements to the center console stack. New for 2006 is the XLR-V high-performance version powered by a supercharged Northstar V-8 engine producing 440 horsepower. It also gets all the requisite suspension and braking enhancements to handle the extra power.\$75,835 to \$85,000 (est.)

CHEVROLET CARS

Aveo — Chevrolet's smallest car, the Korean-built Aveo gets available front side-impact airbags.\$9,455 to \$13,015

Cobalt — New in 2005 the Cobalt replaced the aging Cavalier and has been a welcome addition to the Chevrolet lineup. Available in a sedan, coupe and a supercharged SS version (of both body styles) it competes favorably with its Japanese counterparts.\$14,490 to \$21,990

Corvette — Chevrolet's biggest news for 2006 will produce the smallest sales volume, but will probably garner more press coverage than all the rest of the brand combined. New this year is the ultra high performance Chevrolet Corvette Z06 with a new hand-built 7.0-liter LS7 V-8 engine rated at 505 horsepower. It's loaded with racing-derived equipment and requisite modifications to brakes, exhaust and handling. The Z06 boasts 0 to 60 mph acceleration times of 3.7 seconds and a top speed of 198 mph.\$43,710 to \$65,800

Impala and Monte Carlo — Chevrolet's largest sedan and coupe, the Impala and the Monte Carlo get dramatic engine enhancements. The standard V-6 power comes from a 210-hp 3.5-liter V-6 front-wheel drive, but a new 5.3-liter 303-hp is available for the first time. The V-8 features Displacement-on-Demand technology that cuts off

four-cylinders during light-load conditions and as a result improves fuel economy by up to 12 percent. Both cars have standard four-speed automatic transmissions and new sets of 16-, 17- and 18-inch wheels and tires.\$21,330 to \$28,555 for the Impala\$21,330 to \$28,355 for the Monte Carlo

Malibu and Malibu Maxx — The midsize four-door models get cosmetic changes to differentiate them from the previous model. There is also a new SS version powered by a new 3.9-liter 240-hp V-6 engine.\$17,365 to \$24,205 for the Malibu ..\$21,025 to \$24,755 for the Malibu Maxx

CHEVROLET TRUCKS

Avalanche — The popular Avalanche, with its adjustable cargo area and movable rear cabin wall, called the Midgate, get minor changes and increased towing capacity.\$34,010 to \$42,365

Colorado — Going into the second model year the midsize Colorado has minor enhancements and continues with the broad range of variations. The four- and five-cylinder engines remain unchanged.\$15,095 to \$28,550

Equinox — The popular Equinox compact SUV goes into its second model year with only minor cosmetic upgrades.\$21,320 to \$24,675

HHR — All new for 2006 is the Chevrolet HHR with its retro styling that resembles a miniaturized version of a 1940s Chevy Suburban. It's built on the solid platform of the Chevrolet Cobalt and is designed to compete with the Chrysler PT Cruiser. The LS version gets a 140-hp 2.2-liter Ecotec four-cylinder engine, while the upper level LT gets a 2.4-version rated at 170 hp. Both engines are dual overhead cam configurations with electronic throttle control and standard five-speed manual transmissions or optional four-speed automatics.\$15,995

Silverado — The Silverado, gets more beef for 2006 with increased GVWR, towing and payload ratings thanks to a new VortecMax performance package with a high-output Vortec 6000 V-8 engine and larger rear axle. The Duramax diesel is enhanced and there's a new Allison six-speed automatic transmission on the 2500HD and 3500 models.\$35,590 to \$41,345

Tahoe and Suburban — The Chevrolet Tahoe and Suburban models get simple changes for 2006 in preparation for a total redesign for the 2007 model year. Quadra-steer, the four-wheel steering option, gets dropped for 2006. Suburban will get a new LTZ model with all-wheel drive, 20-inch wheels, monochromatic paint, leather and big Vortec V-8 engine all standard.\$34,115 to \$47,945

KEEP RIGHT >>

Cadillac STS-V



Cadillac XLR



Chevrolet Aveo



Chevrolet Corvette Z06



Chevrolet Impala



Chevrolet HHR



SSR – The retro-styled pickup/roadster got a big power boost to 390-hp for 2005 along with the addition of a six-speed manual transmission. For 2006, Chevy upped the horses again to an even 400, or 395 when equipped with the four-speed automatic transmission. It gets a couple of two-tone color schemes, too.\$39,340 to \$42,555

TrailBlazer – Chevy's mid-level SUV gets a new front and rear fascia, rocker panels and side moldings on the LT models along with a Quiet Package and a single antenna to handle OnStar and XM radio. The Vortec 5300 engine gets a Displacement on Demand system to improve fuel economy. The standard Vortec in-line six-cylinder engine gets 16 more horsepower, up to 291. StabiliTrak stability control system will be standard. Performance buffs will appreciate the new TrailBlazer SS with its unique monochromatic styling and interior enhancements. Look for 0 to 60 mph times of 5.7-seconds thanks to a 395-hp 6.0-liter V-8 engine adapted from the Corvette. The SS is available in two- or all-wheel drive.

.....\$26,465 to \$34,310
Uplander – No longer a minivan, the Uplander crossover sport van has muscular styling that more resembles an SUV than a sleek minivan. It's one of the few midsize vans available with an all-wheel drive option. New in 2005, the Uplander is virtually unchanged for 2006.\$20,700 to \$33,795

CHRYSLER

Crossfire – Chrysler's two-seat coupe and roadster sports cars are mostly unchanged for 2006. Built using many of the mechanicals of the previous generation Mercedes-Benz SLK, the two-seaters are available in standard trim powered by a 215-hp V-6 engine or with the SRT-6 with a supercharged 330-hp V-6.

.....\$30,000 to \$50,500 (est.)
PT Cruiser – The retro-styled PT Cruiser gets significant changes to both the front and rear fascia along with a reworked interior. The GT's high-pressure four-cylinder turbo engine is boosted to 230-hp this year while the other engine choices remain the same with a 150-hp naturally aspired four-cylinder and a light turbo version rated at 180-hp.

.....\$14,850 to \$24,085 for the wagon
\$24,045 to \$29,500 for the convertible
Pacifica – The stylish front- or all-wheel drive wagon features a unique 2-2-2 seating configuration with room for six adults. No significant changes are planned for 2006.

.....\$25,895 to \$37,415
Sebring – Gone for 2006 is the Mitsubishi-based Sebring coupe, but the brand is still represented by the sedan and best selling convertible. A sporty limited edition LSi sedan with ground effects and sport-tuned suspension will be offered, while the convertible

remains unchanged.
\$20,380 to \$23,390 for the sedan
\$26,440 to \$32,050 for the convertible
Town and Country – The king of minivans added the Stow 'n Go seating and storage system last year to keep it as one of the top rated minivans on the market.

.....\$21,735 to \$36,465
300 – As the leader of the Chrysler renaissance the flagship 300 sedan, which won nearly every major award for 2005, will stay mostly unchanged.\$24,200 to \$42,695

DODGE CARS

Charger – As an early 2006 model, the Charger is off to a big start with its bold styling and available 340-hp Hemi Multi Displacement System (MDS) engine that shuts down four cylinders during light engine loads. The standard engine is a potent 250-hp 3.5-liter V-6. New later this year is the high performance SRT8 version with a beefy 6.1-liter Hemi engine producing 425-hp and the capability of 0 to 60 mph runs in 5 seconds. Watch for the special new police version of the Charger and Magnum in your rear-view mirror.

.....\$22,295 to \$35,320
Magnum – With styling that looks like it might have come off from a custom car show, the Magnum moves into its second year. Changes include a revised transmission, tire pressure monitoring system and an optional DVD-based entertainment system. An SRT-8 version with the 425-hp 6.1-liter Hemi engine is available for 2006.\$22,995 to \$37,995

Neon/Caliber – The Neon will be replaced by a five-door called the Caliber. The production version is likely to be a twin of the concept when it arrives at dealerships in the spring of 2006 as a 2007 model. The Caliber will be the first of several products (including the PT Cruiser and larger Sebring replacement) coming from the new front-drive platform developed jointly with Mitsubishi.

.....\$14,800 to \$16,500 (est.)
Stratus – Moving into its last year the midsize Stratus remains mostly unchanged. The V-6-powered R/T gets an updated interior and sporty appearance package plus four-wheel disc brakes. The Stratus is due for replacement and probably a new name when it gets replaced in the spring of 2007 as a 2008 model.\$20,140 to \$24,120

Viper SRT-10 – For the second time in 13 years the Viper Roadster again gets the company of a coupe. Designed with racing in mind, the coupe will employ the same 500-hp V-10 power that produces sub four-second 0 to 60 mph acceleration.\$85,745 to \$86,995

DODGE TRUCKS

Caravan – The sign outside the Dodge store would say more than '11 million sold' making

Chevrolet SSR



Chevrolet TrailBlazer SS



Chrysler Crossfire



Chrysler PT Cruiser



Dodge Charger



Dodge Caliber



the original minivan, the most popular. Innovations like the Stow 'n Go seating and storage system, inflatable knee blocker along with five-star crash ratings and great value keep the Caravan a perennial favorite. It gets minor improvements for 2006.\$19,930 to \$27,100

Dakota – The Dakota lineup is expanded with four new models: TRX, TRX4 Off-Road, R/T and Night Runner.\$20,010 to \$29,510

Durango – Dodge's only SUV gets technological upgrades with the addition of the Multi Displacement System (MDS) for Hemi models along with a new electronic stability control, roll-sensing airbags and power rear liftgate.\$28,200 to \$37,210

Ram – All new from the frame up the popular 1500 pickup offers a full lineup of styles, configurations and drivetrain choices. The new bold styling is evolutionary outside and inside. The Hemi models get MDS.\$21,700 to \$37,170

Ram Mega Cab – With an interior space greater than the large sedans, the new Mega Cab truck offers comfortable seating for six adults along with a maximum interior cargo capacity and flexibility for Ram 1500, 2500 and 3500 models.\$32,760 to \$48,595

Ram Heavy Duty – The bigger Ram trucks get a mild refreshing and new off-road equipment with the TRX4 package.
\$26,085 to \$42,615

Ram SRT10 – The world's fastest production pickup according to the Guinness Book of World Records (143.587 mph top speed), gets a new frame, styling and interior like the other Ram trucks. It is still available in regular and quad cabs.\$46,000 to \$51,000 (est.)

FERRARI

F430 – Ferrari's new models arrive when they are ready and rarely follow the calendar. Introduced in mid-2005 the mid-engine F430 coupe and Spider replaced the Modena as the 'entry-level' Ferrari.\$193,000 to \$210,000 (est.)

612 Scaglietti – The V-12-powered Ferrari four-seater is unchanged.\$250,000 (est.)

600 Imola – This is the rumored name of the replacement for the 575M Maranello which is sold out.t.b.d.

FORD CARS

Five Hundred – New in 2005, the spacious Five Hundred remains the same with a 205-hp V-6 engine as the only choice. Drivetrain choices include a six-speed automatic or a continuously variable transmission and in front- or all-wheel drive. There's talk that it's on the fast track for a redesign to give it a more imaginative and appealing style.
\$22,930 to \$28,930

Focus – Updated in 2005 with fresh interior and exterior designs the Focus is unchanged for 2006 with sedan, wagon, 3- and 5 door hatchback body styles.\$13,995 to \$17,585

Freestyle – As the wagon version of the Five Hundred, the Freestyle is like a more practical application of an SUV with its higher seating position and spacious, versatile interior.\$25,805 to \$31,605

Fusion – Ford's latest and greatest midsize sedan will ultimately replace the Taurus, when people and fleets quit buying it. Designed to compete directly with the Accord and Camry, the front-wheel drive sedan comes with a 2.3-liter four-cylinder and 3.0-liter V-6 producing 160- and 221-hp respectively. The four-cylinder is hooked to a five-speed manual with optional five-speed automatic, while the V-6 is strictly driving a six-speed automatic.\$17,795 to \$22,360

GT – Ford's halo sports car is back, probably still with a waiting list. It just goes to show you that 550 supercharged horses in the middle of light car commands of attention and desire.\$153,500 (est.)

Mustang – The V-6 version is now available with a "GT-inspired" suspension and handling elements. The GT also gets a new handling package and 18-inch wheels. Rear-wheel drive and V-8 power makes the latest pony car the best and greatest value to date.
\$19,810 to \$31,840

Taurus – Unchanged.\$21,515 to \$23,665

Crown Victoria – The full-size sedan gets minor enhancements for 2006.
\$25,285 to \$31,605.

Thunderbird – Dropped after the 2005 model year due to slow sales. We won't be surprised to see it back in the future.

FORD TRUCKS

Escape – Ford's littlest SUV got a timely image boost last year when it was offered as a hybrid. The hybrid is 99.4 percent cleaner operating, on average, than the regular V-6. Hybrid EPA numbers are 36 mpg city and 31 mpg highway using the specially prepared four-cylinder engine and electric motor drivetrain.\$19,995 to \$27,245

Excursion – The biggest SUV, and target of the environmentalists, has been discontinued. It will likely be replaced for 2007 as a stretched version of the Expedition (like the Tahoe/Suburban relationship).

Expedition – Ford's full-size SUV is unchanged for 2006, but is due for a total redesign in 2007.\$33,480 to \$46,060

Explorer – As the granddad of the SUV segment, the latest Explorer has new safety equipment and NVH (noise, vibration and harshness) reduction accomplishments. The styling is bold emulating the larger Ford SUV products. Taking elements from the Mustang and F-150 engines, the new 4.6-liter V-8 engine is rated at 292 horsepower, plus it gets the benefit of Ford's new six-speed

KEEP RIGHT >>

Dodge Ram SRT10



Ford Five Hundred



Ford Fusion



Ford GT



Ford Mustang



Ford Escape Hybrid



automatic transmission. Seven-passenger seating is available.\$27,175 to \$36,585

Explorer Sport Trac – The combination truck/SUV has been discontinued for 2006, but will be back with longer and wider styling as a 2007 model. Watch for a spring introduction.

Freestar – Ford's safety-leading minivan is unchanged for the 2006 model year.

.....\$24,385 to \$30,305

F-Series – All new last year the F-150 gets a new Harley-Davidson trim package with a "menacing monotone black exterior." There are also other minor cosmetic changes.

.....\$19,640 to \$37,300

Ranger – Ford's small pickup gets cosmetic enhancements centered on making it bolder and more aggressive.\$15,085 to \$27,305

Super Duty Trucks – Unchanged.

.....\$23,295 to \$46,090

GMC

Canyon – New in 2005 the smaller Canyon pickup gets minor safety and handling upgrades for 2006.\$15,330 to \$28,385

Envoy – Available in a broad variety of trim levels and two lengths, the midsize Envoy appearance is freshened. GM's Displacement on Demand (DOD) is added to the 5.3-liter V-8 engine. The XUV with its innovative roof-opening cargo area has been discontinued. The Yukon models are scheduled for a re-engineering and restyling for the 2007 model year.\$28,525 to \$40,235

Yukon / XL / Denali / XL Denali – Unchanged.\$34,805 to \$51,935

Savana – Some models of the GMC people and cargo van will get a Duramax 6600 turbodiesel engine option.\$22,860 to \$32,925

Sierra – GMC's full size pickup gets engine improvements including a new VortecMAX performance package for the 5.3-liter V-8 to improve towing capability. The Duramax diesel gets upgrades, too while the Allison automatic transmission gets upgraded from five to six-speeds. The mild Sierra hybrid model, which has the best fuel economy of any full-size V-8, is now being sold nationally.\$18,190 to \$41,735

HONDA

Accord – The popular Accord coupes and sedans get cosmetic enhancements and more power.\$16,295 to \$32,140

Civic – The biggest news at Honda is the introduction of the all-new Civic. Available in four distinct models the larger, more sophisticated Civic comes in sedan, coupe, hybrid and Si versions. Now in its eighth generation, the Civic has a sharply raked windshield and wedge-like profile. The instrumental panel is a stylish and remarkably functional two tier system. Honda says the new Si is capable of 0 to 60 mph acceleration of 7.5 seconds, but

it feels faster.\$14,910 to \$20,810

Si prices had not been announced as of our deadline.

CR-V – Unchanged. It's scheduled for a complete redesign for 2007 or 2008.

.....\$20,195 to \$25,250

Element – Unchanged.\$17,450 to \$21,725

Insight – The two-seat original hybrid is unchanged.\$19,330 to \$21,530

Odyssey – Redesigned in 2005, Odyssey is unchanged for 2006.\$25,195 to \$38,795

Pilot – Honda's midsize SUV gets reskinned, cylinder deactivation on the V-6 engine and a two-wheel drive model.\$27,550 to \$34,320

Ridgeline – Honda's first pickup, Ridgeline was introduced early in 2005 as a 2006 model. With its spacious four-door cabin and innovative cargo bed and under bed trunk.

.....\$27,700 to \$34,640

S2000 – The two-seat Honda roadster gets drive-by-wire throttle control and a stability control system.\$33,150

Honda has plans for a car smaller than the Civic as early as the 2007 model year. The car will likely be named Fit.

HUMMER

H1 – The original massive off-roader, based on the military Humvee, is unchanged. Now called the H1 Alpha it gets power from a 300-hp 6.6-liter Duramax turbo diesel with a five-speed automatic Allison transmission.

.....\$128,374 to \$139,771

H2 – Unchanged.\$52,485 to \$56,225

H3 – Introduced early in 2005 as a 2006 model, the smallest HUMMER is based on the Chevrolet Canyon mechanicals. It's a more reasonable size measuring six-inches lower, 6.5 inches narrower and nearly 17 inches shorter than the H2. The H3 is comfortable, quiet and has relatively peppy performance from the in-line five-cylinder engine.\$28,935

HYUNDAI

Accent – The Accent is the latest version of a Hyundai entry-level sedan. Larger than the previous model the new Accent has a new 1.6-liter four-cylinder engine and sports the same company-wide 10-year, 100,000 mile powertrain coverage that helped put Hyundai in the limelight.\$12,500 (est.)

Azera – Moving the brand upscale, the Azera replaces the XG350. It's longer and wider than the XG and has more interior space and luxury appointments. It's powered by a new 265-hp 3.8-liter V-6 engine with a five-speed automatic transmission with Shifttronic.Under \$25,000

Elantra – The Elantra gets new sheet metal and larger cabin in the fall of 2005. Engines will be a new 235-hp 3.3-liter V-6 and 162-hp 2.4-liter DOHC four-cylinder.\$14,200 to \$16,000 (est.)

Santa Fe – The Hyundai SUV was freshened and upgraded for 2005 and held over for

Ford F-150



GMC Sierra Hybrid



GMC Canyon Crew Cab



Honda Civic Si



Honda Ridgeline



HUMMER H2



2006. A new U.S.-built 2007 model will be coming when the new factory goes on line next year in Alabama.\$21,649 to \$26,099

Sonata – Introduced early in 2005, and unchanged for 2006, the Sonata will offer a strong challenge to the Camry and Accord. Better equipped, filled with technology and fun to drive the Sonata has crisp new styling and it's a top value in the segment.

.....\$16,449 to \$22,895.

Tiburon – The sportiest Hyundai gets a new GT limited model which adds leather seats, power sunroof and powerful Infinity stereo. Engine choices include a four-cylinder and V-6.\$17,000 to \$21,000 (est.)

Tucson – The compact Tucson sport wagon was new in 2005 so no changes are expected for 2006.\$17,499 to \$22,799

INFINITI

FX35 and FX45 – The stylish FX crossover sport utilities get a minor exterior facelift with new grille, bumper and wheel design.

.....\$35,500 to \$44,900 (est.)

G35 – Infiniti's award-winning G35 sedan and coupe both get Bluetooth® hands-free phone systems and satellite radio for all premium packages. The coupe gets standard projector-beam bi-xenon headlights, cosmetic upgrades and available Rear Active Steer system.

.....\$31,500 to \$33,500 (est.)

M35 and M45 – The 2006 model M cars went on sale in February 2005 to rave reviews and have already marked up several comparison wins. The M45 power comes from a 335-hp V-8, while the M35 has a 280-hp V-6. Both rear-drive cars, and the available all-wheel drive M35, have a five-speed automatic transmission. The middle sedans have a high level of standard luxury features like rear-view camera with on-screen tracking guide and interesting hi-tech options like lane departure warning system.\$40,640 to \$49,750

Q45 – New sport model gets Rear Active Steer, sport suspension and 19-inch high-performance wheels and tires, while the lane departure warning system is added to the premium package.\$57,200 (est.)

QX56 – The full-size SUV gets a 60/40 split third row seat, MP3 capability and new heated/folding outside mirrors.\$48,350 to \$52,550

ISUZU

Ascender – The rebadged Chevy TrailBlazer was the only vehicle wearing the Isuzu name tag last year.\$26,000 to \$38,500 (est.)

i-Series – For 2006 the lineup grows to two, but again with rebadged GM vehicles, this time with a four- and five-cylinder Chevrolet Colorado pickups bearing the Isuzu names i-280 and i-350.\$16,989 to \$27,358

BARBARA AND BILL SCHAFFER are co-editors of *Auto Digest* reviews, rumors and other features.

JAGUAR

S-Type – Jaguar's midsize sedan has several cosmetic changes the most noticeable being the chrome mesh grille insert which will now be used on all Jaguars. Bluetooth® and Sirius satellite radio are now available on all models. The V-8 engine horsepower is increased to 300.\$44,230 to \$63,330

X-Type – All-wheel drive is standard equipment on all X-Type sedans and the sport wagon.\$30,330 to \$36,330

XJ – The big luxury sedan gets further refinement including acoustic laminated side glass and a radio-frequency based tire pressure monitoring system for all five tires, including the spare. A limited edition Super V-8 Portfolio LWB (Long Wheelbase) was added for 2006.t.b.d.

XK – The next generation XK 2+2 sports car was unveiled at the Frankfurt auto show recently. With its stunning good looks, all-aluminum construction and advanced technology it should be one of the most exciting Jaguars ever built. Both the coupe and convertible will arrive in the spring of 2006 as 2007 models.t.b.d.

JEEP

Commander – Jeep gets into the seven-passenger SUV market with the new Commander. Riding on the same platform as the Cherokee, the Commander is larger and taller with more interior space and stadium tiered seating for better forward visibility. Engine choices include a 3.7-liter V-6, a 4.7-liter V-8 and the 5.7-liter Hemi engine. Three full-time four-wheel drive systems and two different transfer cases are offered.

.....\$27,290 to \$38,205

Grand Cherokee – Performance is the key addition to the Grand Cherokee lineup for 2006 with the introduction of the SRT8 version powered by a 415-hp Hemi engine. With upgraded suspension, four-wheel Brembo brakes and 20-inch wheels, the SRT8 is capable of 5 second 0 to 60 mph runs.

.....\$26,355 to \$42,230

Liberty – Jeep's middle off-roader comes with a choice of gas or diesel power and remains mostly unchanged for 2006.

.....\$19,480 to \$26,960

Wrangler – Now available in long- and short-wheelbase versions, the off-road favorite is due for a major makeover in 2007.

.....\$18,070 to \$29,290

Future products include the Gladiator pickup based on the Wrangler and two crossovers, the Patriot and Compass, based on the Dodge Caliber.

TO BE CONTINUED - NEXT ISSUE!

Hyundai Azera



Infiniti M45



Infiniti FX45



Jaguar XJ



Jaguar XK



Jeep Liberty



Six Things a Teen Driver Should Never Be Without

Forty percent of teens will be involved in a motor vehicle accident in their first year of driving. Hundreds of thousands will suffer breakdowns and other serious mechanical failures, and thousands will be left stranded—sometimes in extreme heat or cold, or in remote or otherwise dangerous locales. There are at least six things that every teen driver should always have in his or her vehicle, no matter what kind of vehicle it is. Most could save his or her life. Every teen driver should have, and know how to use, these six items, stowed safely in their vehicle at all times:

- 1 A cell phone and safe operating instructions, along with a 12-volt connector/charger. Remember, in most coverage areas, you don't even need a cellphone account. Most cell carriers will respond to 911 calls even for non-registered phones.
- 2 A complete first-aid kit including bandages, antiseptic ointments and first-aid instructions.
- 3 An emergency roadside kit including reflectors, properly packaged flares, a blanket, a compressor or tire-inflator-in-a-can (check the spare once a month) and a basic tool kit.
- 4 A good, weatherproof flashlight with fresh batteries (checked once per month and replaced at least every six months, whether used or not).
- 5 A well-hidden credit card or SMALL amount of money in travelers checks or cash. (You'd be surprised how small you can fold cash, and it can be hidden almost anywhere.)
- 6 An emergency CHEAT SHEET in the glove compartment listing emergency procedures, a list of what to do in the event of an accident and a list of personal emergency contacts (parents, guardians or other important relatives).

Is that all? Not by a long shot, but this is the minimum. The items above could easily save your life. For more information about teen driving, safer vehicles, and other things you should consider, visit:

<http://pull.xmr3.com/p/239-4E4C/78079409/http-www.safecarsforteens.com-.html>

or email: info@safecarsforteens.com

or call 508-358-9109. ■

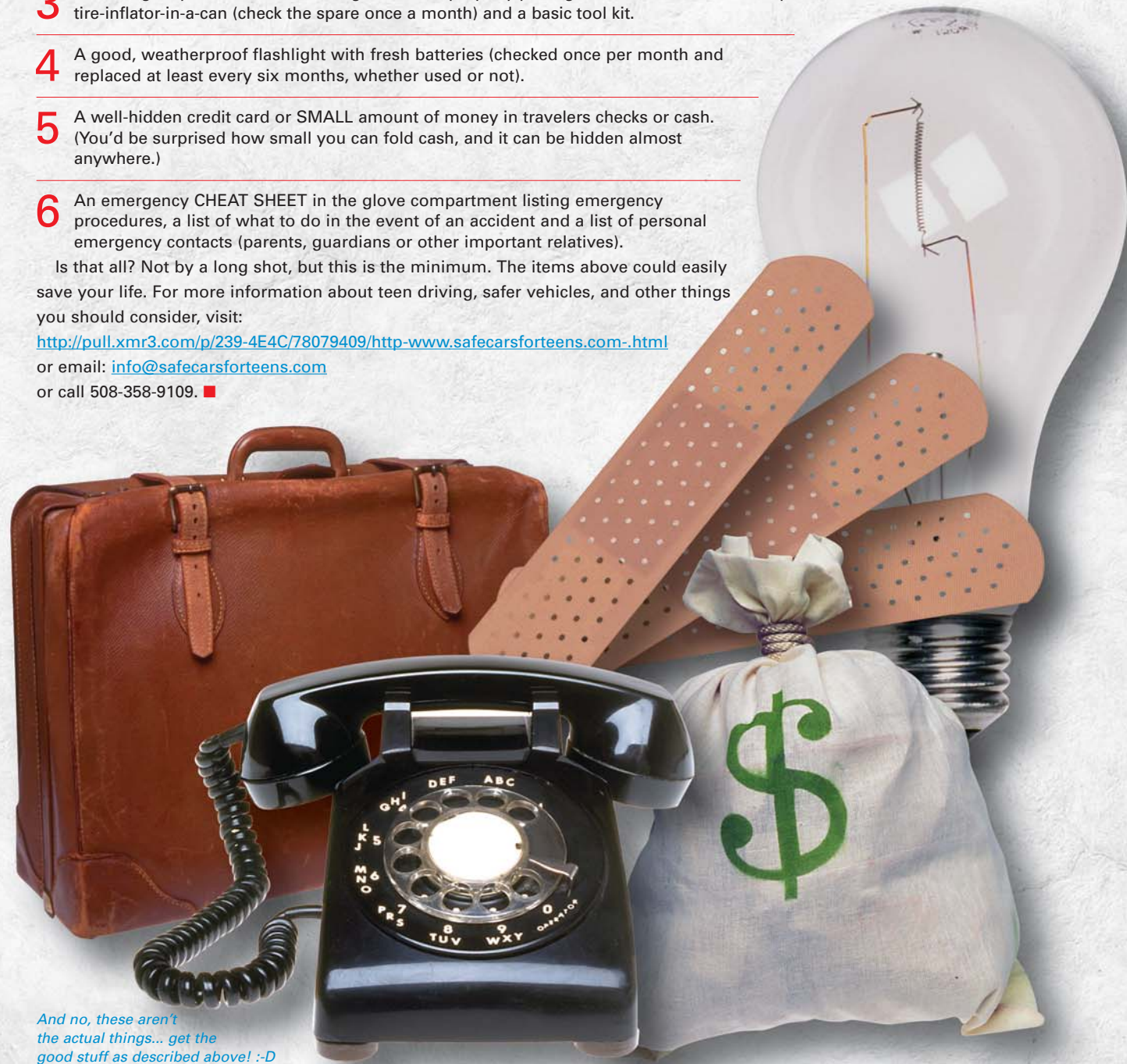

And no, these aren't the actual things... get the good stuff as described above! :-D

Delivering the driver's edge to teen drivers.

Traditional driver's education has focused on the skills needed to pass a driving test, with classroom lectures and some behind-the-wheel "on-the-job training." The DrivingMBA™ program goes beyond this, bringing high-tech simulators to everyday drivers.



The DrivingMBA™ Comprehensive Driving Tutoring Program

These components are available as a discounted package or individually:

- **Rules of the Road® DVD** : Award-winning interactive DVD tutorial for home use.
- **Pre-Permit Driving Simulation Course** : 5 hours total computer simulated driving experience gives teens a solid foundation in fundamentals before they get behind the wheel.
- **Safe Young Drivers** : A book to supplement your own in-vehicle training.
- **Advanced Decision Skill Building** : The same high-end simulator used by police and other professionals to improve behind-the-wheel decision-making skills.
- **Profiler™** : Assesses your skills against a pro database (included with Advanced Decision Skill Building).
- **DUI** : Students in both simulator courses experience the negative impact upon vehicle control of driving while impaired.



A PROGRAM OF ACCELERATED SKILL BUILDERS

www.drivingmba.com

9181 E. BELL ROAD, SUITE 103 • SCOTTSDALE AZ 85260 • 480-948-1648

HUMMER H3: FOLLOWING THE PATH OF ITS FOREBEARS

The HUMMER H1 hit the civilian world by storm and became equally popular in Arizona's rugged terrain and on its urban freeways and resort valet lots. Along came the HUMMER H2, and the balance tipped toward the urban set, though most people didn't suffer any big practical loss in reasonable utility. The HUMMER H3 is poised to be pushed a little farther in the same direction.

By Joe Sage

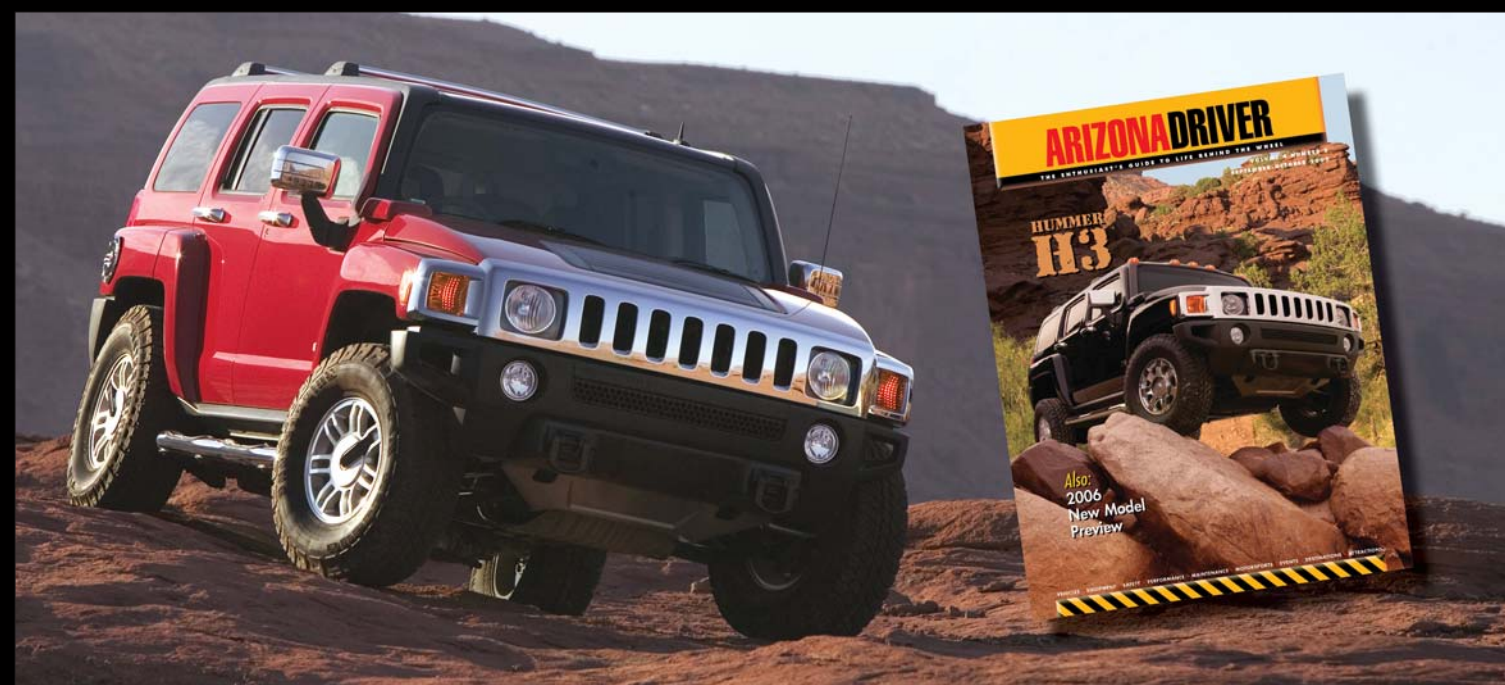
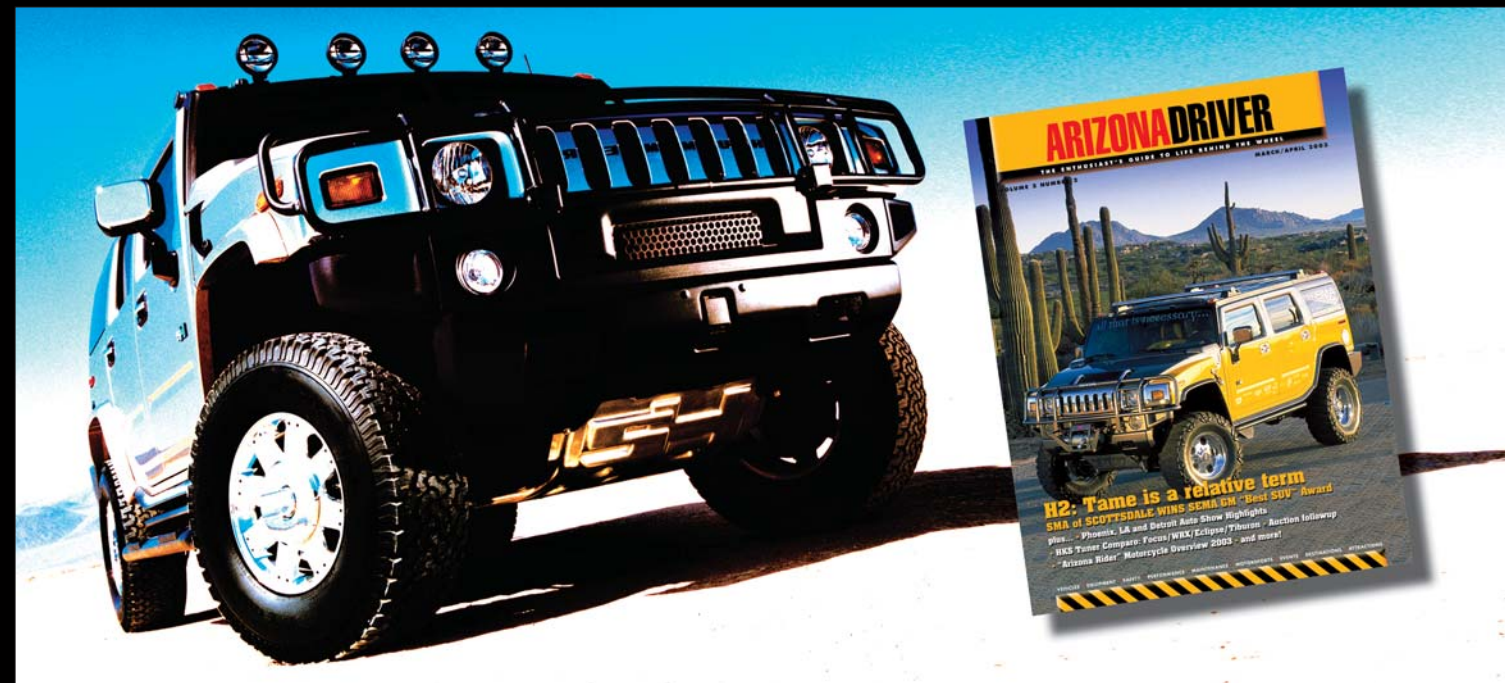



We know that some of you may be thinking: H1, H2, H3—this is the “baby HUMMER.” Well, you’d best be careful what names you call this tough guy. GM committed themselves to continuing an uncompromised HUMMER off-road legacy with the addition of the H3 to the lineup. To get there, they validated the H3’s off-road prowess on some of the world’s most extreme terrain.

“We engineered the H3 with the ultimate off-road experience in mind, challenging it on the toughest trails,” said Todd Hubbard, H3 Ride and Handling Engineer. “The H3 earned its HUMMER badging on trails that defined the capability of its legendary H1 and H2 siblings.”

For three years, development and engineering teams tested the H3 in Box Canyon, Arizona, as well as Moab, Utah, Tellico, NC, Silver Lake Sand Dunes in Michigan, Barstow, California, and the legendary Rubicon Trail, also in California.

Based on testing at Moab and on the Rubicon, engineers added three additional high-strength stamped-steel skid plates to protect the oil pan, front axle, transfer case, and fuel tank. The trails of Moab are scattered with large igneous rock formations, creating opportunities to test the H3’s rock climbing and crawling abilities. The Rubicon Trail is such an intensive training route that its mere 12.5 miles of trail take two days to traverse.

Testing in Tellico, NC, verified the H3’s ability to ford 16-inches of water at 20 mph, through 24-inch streams at a five-mph pace and traverse mud crossings. Tellico also showed an opportunity to reinforce the vehicle’s rock crawling capability.

Michigan’s Silver Lake Sand Dunes offered one of many severe testing surfaces for the vehicle’s tires. The Goodyear all-terrain 32-inch tires, standard on the H3, are the largest standard tires in its class and provide optimum traction with increased approach, departure and break-over angles. Optional 33-inch Bridgestone Dueler A/T tires were developed especially for the H3, which enable the truck to go almost anywhere. The Bridgestone tire features a robust three-body ply construction for that resists punctures from even the toughest off-road terrain, as well as an over-the-sidewall tread design with integrated noise treatment technology for reduced driving noise. They are as big as those originally used on the full-size H2.

In Barstow, engineers meticulously fine-tuned the H3’s suspension to perform well in high-speed desert runs. The long front control arms, which contribute to its wider stance, front and rear micro-cellular urethane jounce bumpers, large 46mm mono-tube gas-charged shocks, and front and rear stabilizer bars, were all tested to ensure they’d hold up under whatever abuse was dealt them.

The process really got down to business when the engineers brought the H3 to Arizona. H3 testing at GM’s Desert Proving Ground near Phoenix, and in Box Canyon through the Woodpecker Mine, then on the Martinez Canyon trails proved the H3’s rocker protection, underbody skid shields, tires, suspension and steering tuning could withstand another round of intense and aggressive off-roading.

The H3 delivers HUMMER style and off-road capability in a midsize package. Just as its legendary H1 and H2 siblings did in the super-size and full-size segments, the H3 is intended to create a new leader in off-road capability among midsize SUVs.

Compared to the H2, the H3 is 16.9 inches shorter in length, 6 inches shorter in height and 6.5 inches narrower. Roughly the same length as a midsize family sedan, H3 comfortably navigates city traffic, yet still delivers HUMMER’s trademark crawling and climbing capability.

POWERTRAIN

Powered by the Vortec 3500 engine with dual overhead cams and variable valve timing, the H3 features a combination of power and greatly improved fuel economy. H3 is projected to reach peak fuel economy of up to 20 miles per gallon.

Specifically designed as a truck engine, the Vortec 3500 3.5L inline five-cylinder offers a combination of power and efficiency. The engine delivers 220 horsepower at 5600 rpm and 225 lb.-ft. of torque at 2800 rpm. In terms of performance, the Vortec 3500 provides the H3 with excellent power and control for off-roading, with comfortable and capable on-road characteristics, including acceleration that equals the V-8 powered H2 in most driving conditions. The Vortec 3500 brings premium features and advanced technologies—including dual overhead cams,

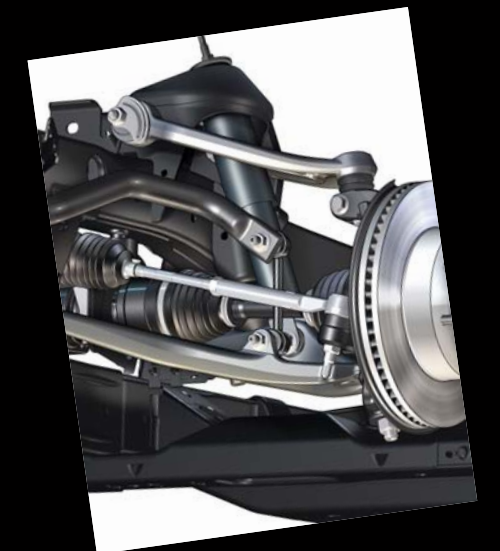



Style meets utility meets burly. The H3T concept truck two years ago caught our eye, and it set the tone for the production H3. GM had said the H3T would follow on the heels of the H3. We hope they keep lots of details from the concept on this one.

variable valve timing, electronic throttle control and low mass. The engine also features unique counter-rotating balance shafts to help minimize noise, vibration and harshness.

The H3 is available with a standard, smooth-shifting five-speed manual transmission—the first manual in a HUMMER—or a Hydra-Matic 4L60-E electronically controlled four-speed automatic transmission. The automatic includes shift modes specific to low-range operation, which, combined with speed-based throttle progressions, help optimize driveability in low-range, off-highway operation.

At the heart of the truck's capability is electronically controlled four-wheel-drive, a standard new Borg-Warner two-speed electrically controlled full-time four-wheel-drive system with a 2.64:1 ratio low-range gear reduction for highly controlled off-road obstacle climbing. An optional version provides aggressive low range gearing—a 4.03:1 ratio—for ultimate obstacle-climbing control. This is augmented with fully locking rear differential, traction control, underbody shielding and GM's StabiliTrak vehicle stability enhancement system.

CHASSIS

Key chassis features that contribute to a combination of smoothness and control, both on- and off-road, including:

- A fully welded ladder-type frame, with a modular, three-piece design that incorporates fully boxed components for outstanding strength and stiffness.
- An independent front SLA torsion bar suspension and "Hotchkiss" design multi-leaf, semi-elliptic, dual stage leaf spring rear suspension. The standard suspension provides excellent on-highway comfort and outstanding off-road capability, while the optional Off-Road Adventure package delivers more extreme off-road capability.
- Four standard protective underbody shields, including the front skid plate; an oil pan skid plate that also protects the front axle; and a transfer case shield and a fuel tank shield. Optional chassis-bolted rocker panel protectors are also available.
- A highly sophisticated standard power rack-and-pinion steering system, with a three-bushing design and a 17:1 ratio that contributes to a very maneuverable 37-foot curb-to-curb turning circle.
- Electro-hydraulic four-wheel anti-lock

disc brakes with Dynamic Rear Proportioning, for quick, controlled stops.

- Standard single-wheel, full-function traction control that uses a combination of engine intervention and brake management to allow as many as three wheels on a slippery surface and still provide impressive traction capability. It also interacts with the transfer case to provide additional off-road operating modes.
- StabiliTrak vehicle stability enhancement system, which enhances safety, stability and control on all roads.

STYLE & FEATURES

The H3's distinctive look comes from such things as a protective aluminum front skid plate; hefty, stamped-steel front and rear bumper bars; a composite front fascia, with "HUMMER" molded into the driver's side; standard front tow hooks; and a welded-on rear bumper recovery hook.

A large rear swing gate encompasses fixed glass, standard rear wiper, defogger and full-size spare tire. HUMMER's first swing gate-mounted spare enhances interior cargo room. A chrome gas filler cover reflects the trademark wheel style.

The H3's interior is inviting, with a perforated, leather-wrapped and stitched steering wheel and automatic transmission shift handle; bright-accented instrumentation; brushed, machine-finished trim plates; chrome door release handles; chrome bezel for the automatic transmission shifter; and a chrome H3 emblem in the center of the steering wheel.

Sporty front bucket seats and 60/40 split rear seats, with foam inserts and soft bolsters, provide both comfort and good off-road operating support, available in standard cloth and optional leather.

The instrument panel is positioned to ensure an optimal view of the road, with easy-to-read liquid crystal displays and a driver information center in the center of the cluster. A center stack includes four levels of controls arranged for easy use.

Four audio and navigation systems are available, all compatible with GM's OnStar system and optional XM Satellite Radio.

We first approached the impending H3 with pretty much the attitude mentioned at the start of this feature: ho-hum, a baby HUMMER. Now that we've been exposed to its, we are more than a little impressed by a vehicle which has evolved to rock-solid on- and off-road capability. ■

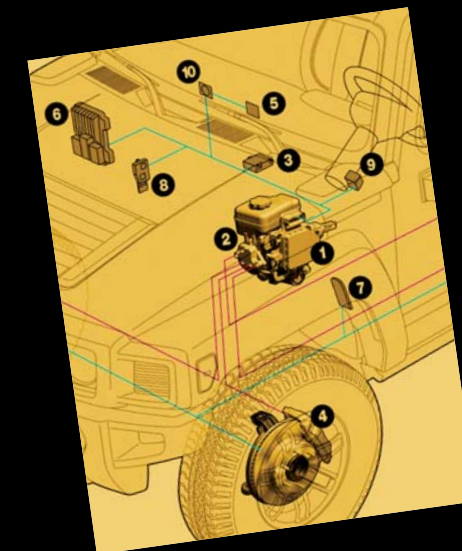

NOW THERE'S A HUMMER FOR EVERY PRICE RANGE

The new smaller HUMMER H3 is more agile than the larger off-roaders and has a 37-foot turning radius, making it about on the same level as a compact car. But check out what it can do with two feet of water or a flight of stairs.

By Barbara and Bill Schaffer



The first HUMMER to come on the scene was almost the size of a locomotive and just about as strong. The HUMMER H2 was a better size than the original but still too large. Now that the HUMMER H3 is off the drawing board and onto the streets, we think it is the perfect size, even though Arnold Schwarzenegger would more than likely disagree with us.

With only a few possible exceptions, there is no vehicle more recognizable than the HUMMER. We've seen men, women and children, with no overt interest in cars, recognize, identify or ask about the HUMMER. Since the original HUMMER went on sale in 1992, its unique design and hulking mass has made it stand out on roads and in parking lots. General Motors bought the name and took over marketing and distribution rights for HUMMER in 2002. Shortly thereafter they introduced a second and slightly smaller model called the H2, and the original was given H1 nomenclature. The H2 became an overnight success, with sales reaching 25 to 65 times more than the H1, and they recently passed the 100,000 sold mark. With H1 pricing starting at \$130,000 and the H2 at \$54,000, the new H3 looks like an economy car with its base price of only \$29,500.

The H3 has all the aesthetics of the H1 and H2, even though it's built on the same platform as the Chevrolet Colorado and the GMC Canyon. This is how General Motors has been able to keep the price down so it is more affordable for the average buyer. The exterior features large wheel wells, grille guards, huge tailgate-mounted spare tire and roof racks, giving it a hunky military look. There is nothing military-like in the interior, which features a more refined yet extremely sturdy look. Controls are logically placed and the dash is clean and uncluttered.

In size, the H3 is like a 91 percent version of the H2 in nearly every dimension. It weighs 4,700 pounds, compared to the 6,400 pounds for the H2. Because it's based on the same platform as the mid-size Chevrolet Colorado pickup, it has the same solid rear axle and independent front suspension. The engine is the inline five-cylinder Vortec, producing 220 horsepower. The H3 is the first HUMMER to be available with either a five-speed manual or four-speed automatic transmission.

Just because it's smaller and less

expensive doesn't mean that it's not as capable off road as the other HUMMERS. It has an electronically controlled four-wheel drive system with traction control and skid plates. StabiliTrak stability control system and a rear locking differential are optional. The H3 offers two tire packages: a 32-inch, all terrain tires and a Bridgestone 33-inch off-road tire.

The H3 comes equipped with many conveniences and features to make this macho-looking SUV a little more civilized. It has standard air conditioning, remote keyless entry, cruise control, power windows and door locks, AM/FM stereo with CD player, power adjustable outside mirrors that can be manually folded plus a compass and outside temperature gauge for just \$28,935.

Our test H3 also came equipped with optional four-speed automatic transmission with stability control (\$1,695), stereo with in-dash CD changer (\$845), power sunroof (\$800), XM satellite radio with three months service (\$325), trailer hitch and wiring harness (\$270), carpeted cargo area floor mat (\$145), front and rear oversized floor mats (\$100) for \$34,400 including delivery.

There is also a dealer-installed chrome package available that includes roof rack, door handles and exterior mirror caps for \$850 that finishes it off nicely.

On road, the big H3 was faster than we expected for having only a five-cylinder engine. Zero-to-60 mph times are listed at 8.9 seconds, and we recorded 71 mph in our benchmark acceleration test of about one-eighth mile. Hard acceleration comes with a lot of engine noise, but it seems appropriate for this vehicle. Under normal cruising conditions, the inside feels solid and is very quiet considering the rugged tire pattern. EPA fuel economy is rated at 16 mpg for city driving and 19 on the highway. We averaged toward the bottom end, 16.1 mpg during our drive time.

Off road, we're told the H3 can ford 16 inches of water at 20 mph or 24-inch streams at 5 mph. It will also climb over steps or rocks up to 16 inches high.

Standard safety features on the HUMMER H3 include dual front seat airbags, four-wheel disc brakes with ABS, OnStar with one-year free service, fog lamps, tire pressure monitor, theft deterrent system plus a few additional safety items.

HUMMER H3

STANDARD EQUIPMENT

Traction control; Keyless entry; OnStar communications system; Tire pressure monitor; Air conditioning; Cruise control; Electrochromic mirror with compass and temperature; Power windows and locks; AM/FM/CD stereo; Underbody shields.

Base Price: \$28,935
 Options: 4-Spd. automatic transmission with StabiliTrak stability control.....\$1,695;
 Chrome package (Roof rack, Door handles, Mirrors).....\$850
 AM/FM with 6-disc in-dash CD changer and 7 speaker Monsoon stereo with rear amp and woofers.....\$845
 Power sunroof.....\$800
 XM Satellite Radio.....\$325
 Trailer hitch and wiring harness.....\$270
 Cargo area carpeted mat.....\$145
 Carpeted floor mats.....\$100
 Chrome assist steps.....\$695
 Total Options.....\$5,725
 Freight.....\$565
 Price as Tested.....\$35,225

DIMENSIONS

EPA SizeSpec. Purp
 Weight.....4,700 lb.
 Wheelbase.....111.9 in.
 Length.....186.7 in.
 Width.....74.7 in.
 Height.....74.5 in.
 Fuel Capacity.....23 gal.
 Cargo Capacity.....29.5 to 55.7 cu. ft.

MECHANICAL

Engine.....3.5L DOHC In-line 5 cyl.
 Horsepower.....220@5600
 Torque.....225@2800
 Transmission.....4-Spd. Auto
 Drive.....Four wheel
 Brakes.....Disc ABS
 Tires.....265/75R16

PERFORMANCE

0 to 60 mph.....8.9 sec.
 EPA economy rating.....16/19 mpg
 Our actual fuel econ.....16.1 mpg

COMPETITORS

Buick Rainier, Chevrolet TrailBlazer, Dodge Durango, Ford Explorer, GMC Envoy, Honda Pilot, Jeep Grand Cherokee, Mercury Mountaineer, Nissan Pathfinder, Saab 9-7X, Subaru B9 Tribeca, Toyota 4Runner

For those of you who lusted for the beefy H1 or the hefty H2 but couldn't afford one, take a look at the H3. It's a great alternative for a heck of a price. We expected to be underimpressed by the new HUMMER H3, but ended up loving it. With its square cab and short windows we felt as if we were driving a box with windows cut in it, but once we got used to that we enjoyed the civilized manner and comfortable cab. And at prices starting under \$30,000 it's very affordable. If high gas prices don't hurt it too bad, you can expect to see lots of HUMMER H3s on the road. ■

THE INSIDE TRACK: BRIEFS & RUMORS

■ **Saab** is adding a SportCombi to its lineup in the fall of 2005. Fitting somewhere between a wagon and a hatchback, the SportCombi will retain the



Saab SportCombi

trademark Saab quirkiness, like a floor-mounted ignition key. Power will come from a 210-hp turbocharged four-cylinder with an optional 250-hp 2.8-liter V-6. Prices will start under \$30,000 with and it will be available in three models, the Linear, Arc and Aero.

■ **Chrysler** plans to change the transmission used with the 2006-model V-6 models of the Dodge Magnum and Chrysler 300 from the current 4-speed automatic to a five-speed. The five-speed will improve performance and fuel economy with a smoother operation and fewer upshifts and downshifts when driving through the mountains.

■ **Porsche** has confirmed that the Cayman S coupe will go on sale in January 2006. Slotted between the 911 Carrera and the Boxster, it has design cues from both Porsche's but with a more stylized sweeping look. The price of the Cayman S will be \$58,900. Power will come from a 295-hp 3.4-liter horizontally opposed six-cylinder engine with a choice of six-speed manual or five-speed Tiptronic automatic. It also has generous 9.2-cubic feet of rear storage space.



Porsche Cayman

■ Watch for **Cadillac** to introduce a smaller SUV called the BRX at the next Detroit auto show. It will be based on an upgrade version of the Chevrolet Equinox, and will like use the 2.8- and 3.6-liter engines from the CTS sedan.

■ **Paramount's** amusement parks in Cincinnati and Toronto have a new ride based on the 2003 movie *The Italian Job*. Ride engineers got technical assistance from Mini to help them replicate the feeling of riding in a Mini Cooper S as it races down

stairs, crashes through a billboard and splashes down into a replica of a Los Angeles aqueduct in the new roller-coaster ride called *The Italian Job Stunt Track*.

■ **Volkswagen** has confirmed it plans to issue a mild hybrid version of the new Jetta within two years. The system will use an electric motor to assist the gasoline-powered engine, which is similar to the system used by the Honda Hybrid.

■ **General Electric** has introduced a new line of replacement automotive headlight bulbs. The ultra-bright Nighthawk™ bulbs, on average, provide a 38 percent

increase in brightness compared to GE's standard original-equipment halogen bulbs and a 17 percent increase for fog lights.

■ The next generation **Volkswagen** Passat goes on sale late this summer with an entirely new architecture and sizing. Previously based on the Audi A6 platform, the new Passat gets it's own for 2006 and it's 2.4-inches longer and nearly 3 inches wider but with nearly the same 106.6 inch wheelbase. The largest available engine is a new 3.6-liter 280-hp V-6. Styling looks similar to a scaled down version of the flagship Phaeton.

■ With the great success of the Nissan 350Z and the Infiniti G35 as incentive, **Toyota** is rumored to be working the fifth generation of the Supra sports car. Inside sources have indicated the curvy coupe will



Lexus LF-A concept

be smaller than the Lexus LF-A concept supercar shown recently and will definitely be rear-wheel drive with a V-8 engine.

■ Production of **Honda's** new Ridgeline sport utility truck has been increased from a planned 230 vehicles per day to 330 to meet better than expected demand. At current sales levels Honda will sell 80,000 Ridgelines annually.

■ **Toyota** is working on a humanoid robot that will compete with the Asimo robot being developed by Honda. According to Automotive News, Toyota has plans to produce robots to work in homes and offices to fill jobs where there are currently labor shortages. Toyota expects to have the mechanical devices available by 2010 to do work like being receptionists for dealerships and as hosts offering beverages to customers.

■ Initial sales of the 2004 **Pontiac** GTO were far below projections, so Pontiac added two scoops to the hood and 50 horsepower to the engine (it's now 400-hp). Sales of the 2005 model are running up 76.9 percent and they expect to sell 12,000 to 14,000 of the high performance coupes by the end of the year.

■ The New New Beetle by **Volkswagen** debuts as a 2006 model with a standard 2.5-liter 150-hp 4-cylinder engine replacing the current 2.0-liter 115 hp engine. The styling is bolder, but still very much



Volkswagen New Beetle Convertible

Beetle. It also gets standard traction and stability control systems when it arrives at dealerships in September.

■ **Mazda** has indicated they will build a car based on the MX-Crossport concept shown at the Detroit auto show last January. To be called the CX-7, it will be built on the same platform as the Mazda6. Many of the design features of the concept such as the low, wide body with RX-8-style fenders will find their way onto the production model. It is expected to arrive at dealerships by spring 2006.

■ The new dramatic new central intake "face" of the **Subaru** B9 Tribeca is expected to be the new Subaru "look" for the entire Subaru line. Watch for it to dress the front of the 2006 Impreza when it arrives in August.

■ Look for **BMW** to offer a turbodiesel-powered sport utility vehicle in the United States within two years. According to Burkhard Goeschel, BMW product chief, it will arrive in the 2007 model year when the low sulphur fuels are made available and the automakers face stricter particulate standards.

■ **Volkswagen** is rumored to be working on an SUV smaller than the Touareg. It will be built on the platform of the Golf Plus, a high-roof crossover currently being sold in Europe. The five-passenger vehicle uses a re-engineered version of the Golf 4Motion all-wheel-drive system. The little off-roader is expected to come to market in 2006 as a 2007 model.

■ In an effort to try to recover lost ground **General Motors** will replace current model minivans in 2008 with radically redesigned models. Chevrolet Upland and Pontiac Montana SV6 models will be available in a regular length with an extended version coming a year later. The future of the Buick Terraza and Saturn Relay vans is still up in the air, with both models likely to be dropped after the 2007 model year.

■ **Pontiac** engineers are rumored to be working on an intercooled turbocharged version of the upcoming Solstice sport car. In addition to the 250-hp Ecotec four-cylinder engine it will get dual exhaust and a six-speed manual transmission. Look for it to go on sale in 2006 as a 2007.

■ Due early in 2006 the replacement **Land Rover** Freelander is based on a longer, stronger platform than the Volvo S40, V50 and Mazda3. It's also shares its

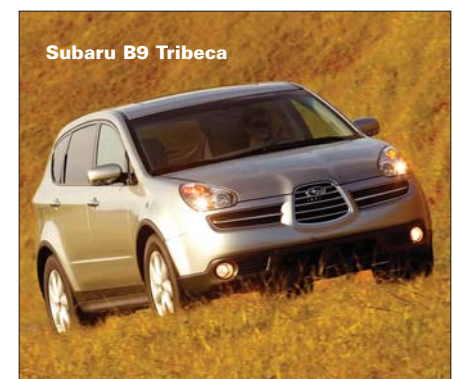

Subaru B9 Tribeca

platform with the upcoming Ford Mondeo and Galaxy as well as the Volvo S60 sedan. The Freelander will be more upscale and sportier, too. Power will be provided by an in-line six-cylinder rated at about 270-hp.

■ Watch for **BMW** to produce a "four-door coupe" similar to the Mercedes-Benz CLS Series and possibly a Sport Activity Coupe that would be like the CLS with a

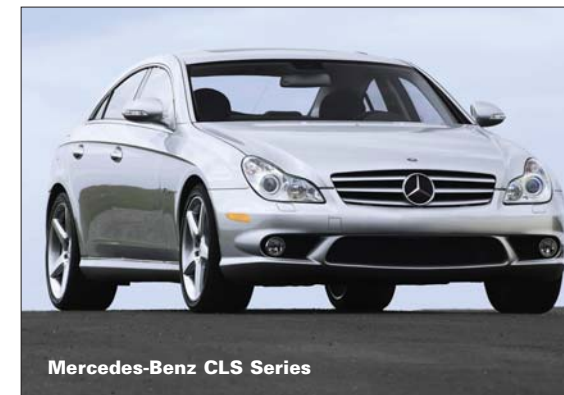

Mercedes-Benz CLS Series

higher ground clearance, all-wheel drive and height-adjustable air suspension. Road & Track magazine says the rumored sleek pair would probably come with a 3.0-liter in-line six-cylinder engine, and 4.0- and 4.8-liter V-8s. An M-version would probably get the new BMW 5.0-liter V-10.

■ **Ferrari** is giving selected buyers of their ultimate new supercar, the FXX, some special privileges. The company is planning a series of track events over the next two years where Ferrari technicians will monitor clients' driving experiences to gather data for future models. The price of admission is \$1.8 million for the 6.2-liter 800-hp Ferrari FXX. The first 20 cars will be delivered by the end of this year "after a careful client selection process," says Ferrari.

■ **Lexus** is rumored to be working on a high-performance version of the LS to be called the LS 600h. In addition to producing 400 horsepower from the V-8 engine, it will add an additional 100 hp from an electric hybrid motor system. Lexus reasons that they than can upgrade the big sedan's sportiness while improving its environmental sensitivity quotient The LS 600h should be able to go head to head with cars like the Mercedes-Benz S65 AMG while getting respectable fuel economy. ■

Briefs & Rumors is a summary of auto news from industry sources, trade journals and consumer magazines compiled for *Arizona Driver Magazine* by **BILL & BARBARA SCHAFFER** of *Auto Digest*.

New 2006 Harley-Davidson Screamin' Eagle Ultra is industry's first motorcycle equipped with XM Satellite Radio as a standard feature

By Barbara & Bill Schaffer



XM Satellite Radio, the nation's leading provider of satellite radio with more than 4.4 million subscribers, enters the motorcycle market with Harley-Davidson's exclusive 2006 FLHTCUSE Screamin' Eagle Ultra Classic Electra Glide, the first-ever motorcycle model equipped with a standard XM Satellite Radio. XM Radio is part of the Screamin' Eagle Ultra's standard Advanced Audio System by Harmon/Kardon. In addition, XM Satellite Radio can be added as an accessory feature to the standard Advanced Audio System found on Harley-Davidson's 2006 FLHX, FLHTC, FLTR and FLHTCU models, giving Harley touring riders the freedom to cruise commercial free from coast

to coast. Each XM-equipped model will include three months of complimentary XM service.

With 20 watts of fully utilized power per channel and an easy-to-read digital display, the AM/FM/XM-ready/ WB/CD-MP3 system provides superlative sound and function for the base radio, and is designed to integrate seamlessly with a number of new Harley-Davidson electronic accessories. It also includes a high resolution display with adjustable background color which can show XM channel playing as well as artist name and song title. An optional 40-watt-per-channel amplifier further boosts performance of the audio system, and a rider-to-passenger intercom with push-to-talk hand controls and headset receptacles can also be added for easy communication while on the road.

Motorcycle enthusiasts had their first opportunity to experience the new 2006 Harley-Davidson Screamin' Eagle Ultra Electra Glide equipped with XM at the annual Sturgis Rally near Rapid City, SD in August, where more than 800,000 enthusiasts converged. Beginning with the 2006 model year, XM-equipped Harley-Davidson Authorized Rentals bikes will also be offered through select Harley-Davidson dealers, and in-showroom XM kiosks at many dealers will allow Harley owners to hear live XM programming.

Broadcasting live daily from studios in Washington, DC, New York City and Nashville at the Country Music Hall of Fame, XM's 2005 lineup includes more than 150 digital channels of choice from coast to coast: commercial-free music channels, premier sports, talk, comedy, children's and entertainment programming and advanced traffic and weather information for more than 20 major metro areas. XM was named Best Radio Service at the 2004 Billboard Digital Entertainment Awards.

XM is available in more than 120 different vehicle models for 2005. XM's industry-leading products are available at consumer electronics retailers nationwide. For more information about XM hardware, programming and partnerships, visit www.xmradio.com ■

Performance Tires & Wheels

Tirexchange, Inc.

Tires • Wheels • Chrome Plating
15485 N. 84th Street • Scottsdale
1-800-766-2588 • 480-596-9655

Driver Tutoring

DrivingMBA™

Comprehensive simulator tutoring for teens
A program of Accelerated Skill Builders
480-948-1648 • www.drivingmba.com

Custom Garage Interiors

GarageTek

Call to visit our completely furnished garages
623-580-0900 • www.garagetek.com

Mobile Communications

NEXT Technologies, LLC

Integrated Mobile Media Environment (IMME)
602-370-0098 • www.NextTech.biz

Mobile Broadband Internet

Sunangel Communications, Inc.

2-Way Mobile Broadband Internet
480-905-1663 • www.broadbandonwheels.com

Mobile Detailing Service

Waxwerks Detailing

Detailing - Valley Wide Mobile Service
Classic, Muscle & Luxury Autos
Ken Dickson • 602-788-9680
www.waxwerksdetailing.com

Aftermarket Enhancements

Gorilla Motorsports

Performance packages - superchargers - A/V
Custom interiors - wheels/tires - suspension
1425 S. Clark Drive • Tempe AZ 85281
408-507-0999 • www.gorillamotorsports.net

Vehicle Diagnostics

AutoXray

EZ-Scan 6000 Automotive Scanner
www.obd2can.com

Auto Dealers

Aston Martin North Scottsdale

18088 N. Scottsdale Road • 480-538-4200

Audi North Scottsdale

18088 N. Scottsdale Road • 480-538-4000

BMW North Scottsdale

18018 N. Scottsdale Road • 480-538-3900

Lou Grubb Ford

8555 E. Frank Lloyd Wright • 480-991-3333

MINI North Scottsdale

18018 N. Scottsdale Road • 480-538-6464

Porsche North Scottsdale

18000 N. Scottsdale Road • 480-538-3850

Scottsdale Lamborghini

Raintree & Hayden Road • 480-483-9300

Van Chevrolet

8585 E. Frank Lloyd Wright • 480-991-8300

Auto Dealers - Specialty

Dream Machines

14825 N. 82nd St. Suite C • 480-951-9524

Gorilla Motorsports

Select line of vehicles restyled for performance
1425 S. Clark Drive • Tempe AZ 85281
408-507-0999 • www.gorillamotorsports.net

Motorsports of Scottsdale

The Finest Collection of Pre-Owned Luxury Autos
Raintree & Hayden Road • 480-483-9300

Scottsdale Lotus

8355 E. Raintree Suite 170 • 480-922-6242

Online Classic Car Classifieds

ClassicCars.com

Put your classifieds online at
480-460-8800 • www.classiccars.com

Racing Events

SCO Nights

Sport Compact Drag Racing
Every Thursday at Firebird Raceway
www.dragracing.com/sco

Phoenix International Raceway

602-252-2227 • www.phoenixraceway.com

High Performance Schools

Bob Bondurant School of High Performance Driving

Mention Code AZ803 for discounted multi-day
1-800-842-RACE • www.bondurant.com

Automotive Fine Art

Automotive Fine Art by Don Evenson

Private commissioned paintings in oil or acrylic
11259 E. Via Linda • Suite 100-185
Scottsdale AZ 85259 • 480-661-8410

Auto Spa / Convenience / Gas

Cobblestone Auto Spa & Market

SCOTTSDALE:

• Frank Lloyd Wright & Hayden • 480-596-1200
• 15111 N. Hayden Road • 480-561-2622

PHOENIX:

• Bell Road & Piestewa Parkway • 602-787-0035

CHANDLER - *Opening in September:*

• Alma School & Germann • 480-814-9274

SURPRISE - *Coming soon!:*

• Bell Road & Grand Avenue

Service & Repair

Airpark Auto Service

8115 E. Raintree • 480-998-1605

Greulich's Auto Repair

8180 E. Raintree • 480-483-8186

Motorcycle Dealers

Cycle-Moto

Aprilia - Ducati - Motoguzzi - Triumph
330 E. Southern Ave # 37 • Mesa AZ 85210
480-898-0559 • www.azsbk.com

Motorcycle Manufacturers

Aprilia Motorcycles - Scooters

www.apriliausa.com

Dan Gurney Alligator Motorcycles, Inc.

Dan Gurney's All American Racers, Inc.

2334 S. Broadway • Santa Ana CA 92707
714-540-1771 • www.allamericanracers.com

Kawasaki Motors Corp., U.S.A.

9950 Jeronimo Road • irvine CA 92618
949-770-0400 • www.kawasaki.com

Triumph

385 Walt Sanders Memorial Drive
Newna GA 30265
678-854-2010 • www.triumph.co.uk

Information is derived from a variety of sources and may not be final or accurate; check all info. Listings do not necessarily represent any specific affiliation with nor endorsement by Arizona Driver magazine.



UPCOMING FEATURES

2006 New Model Year Preview - Part 2



We hope you enjoyed Acura through Jeep in this issue. If you might be interested in a vehicle from the other 61.5% of the alphabet, check back in the next issue, for Kia through Volvo.

Ford GT Special Edition



As though the Ford GT supercar were not more than enough to get your attention, interrupt your sleep and affect your financial planning already, here comes the Special Edition.

Mercury Mariner "Hybrid Patrol" Law Enforcement Contest



Ford is letting law enforcement departments across the US vie for a Mercury Mariner Hybrid small SUV as the prize in a fuel economy faceoff. Arizona departments are in the game.



